

---

**RR 4T ENDURO 2011**

**350/400/450/520**

**RR 4T ENDURO FACTORY**

**400/450/520**

**CATALOGO PARTI DI RICAMBIO**

**CATALOGUE OF SPARE PARTS**

**CATALOGUE PIECES DE RECHANGE**

**ERSATZTEILKATALOG**

**CATALOGO DE PIEZAS DE REPUESTO**



**TAV.1 Carter completo - Crankcase, assy - Carter complet - Kurbelwellengehäuse, KPL. - Carter completo**

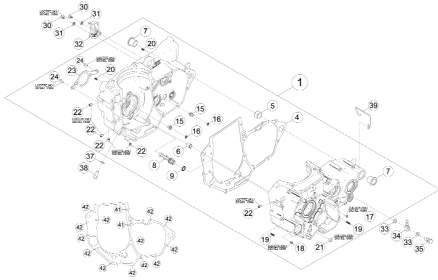

**TAV.3 Albero bilanciamento - Balancer Shaft - Arbre Equilibrage - Ausgleichswelle - Árbol Equilibrado**

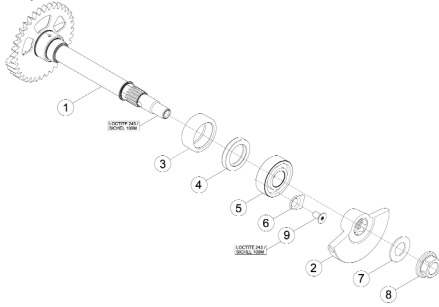

**TAV.2 Coperchio frizione - Clutch cover - Couvercle d'embrague - Kupplungsdeckel - Tapa embrague**

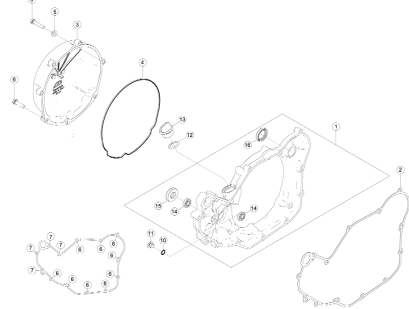

**TAV.4 Albero motore - Crankshaft - Vilebrequin - Kurbelwelle - Cigüeñal**

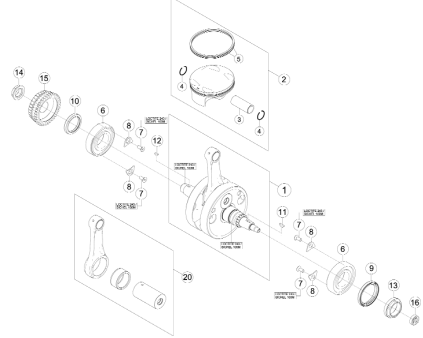

**TAV.5 Frizione - Clutch - Embrayage - Kupplung - Embrague**

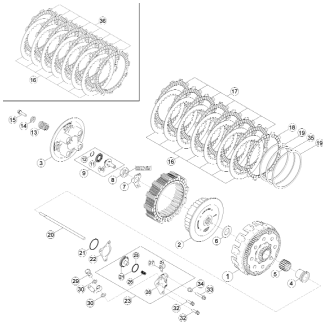

**TAV.6 Ingranaggi cambio - Gear group - Engrenages changement de vitesses - Schaltgetriebe - Engranaje del cambio**

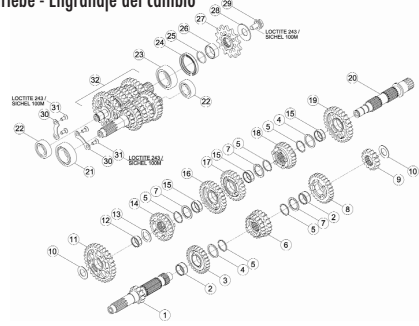

**TAV.7 Comando cambio - Gear shift control - Commande changement de vitesse - Chaltung - Mando cambio**

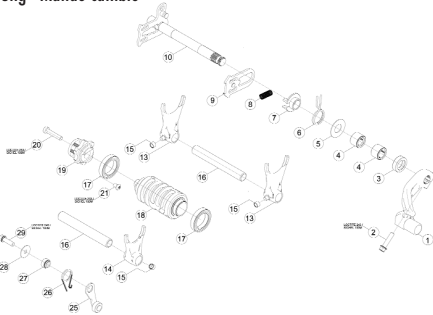

**TAV.8 Avviamento a pedale - Kickstarter - Démarrage à pedal - Pedalstart - Arranque a pedal**

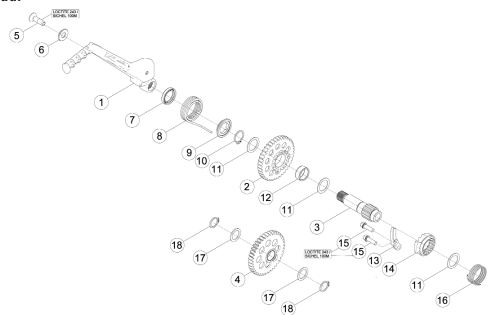

**TAV.9 Avviamento elettrico - Electric starter - Démarrage électrique - Elektrischer start - Arranque eléctrico**

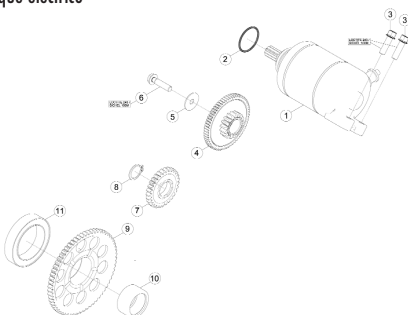

**TAV.10 Impianto di lubrificazione - Lubrication system - Système de lubrification - Schmieranlage - Sistema de lubricación**

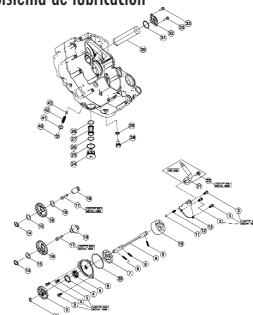

TAV.11 Pompa acqua - Water pump - Pompe a eau - Wasserpumpe - Bomba agua

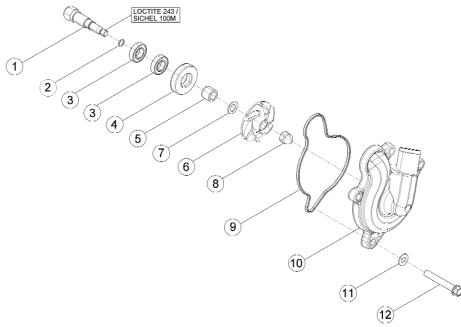

TAV.12 Gruppo accensione elettronica - Electronic ignition assy. - Groupe allumage électronique - Elektronhezünduk gruppe - Grupo encendido electrónico

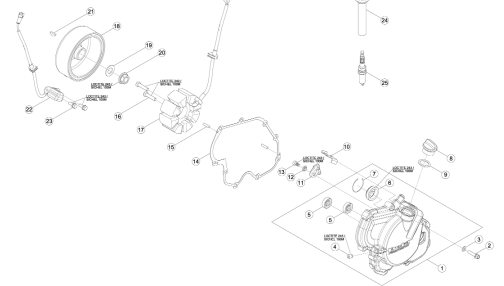

TAV.13 Cilindro completo - Cylinder, assy - Cylindre complet - Zylinder, KPL. - Cilindro completo

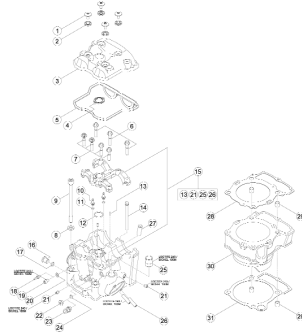

TAV.14 Valvole-Catena distribuzione - Valves-Timing chain - Soupapes-Chaine de distribution - Ventil-Steuerkette - Válvulas-Cadena de distribución

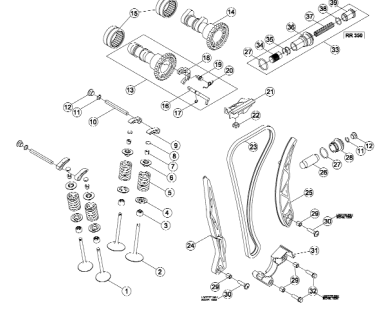

TAV.15 Carburatore - Carburettor - Carburateur - Vergaser - Carburador

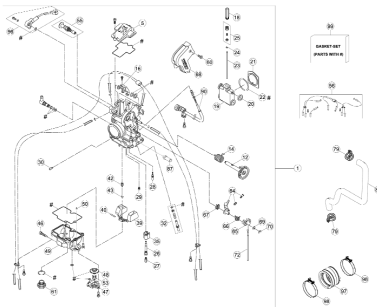

TAV.16 Attrezzatura specifica - Special tools - Outillage spécial - Spezialwerkzeug - Utillaje específico

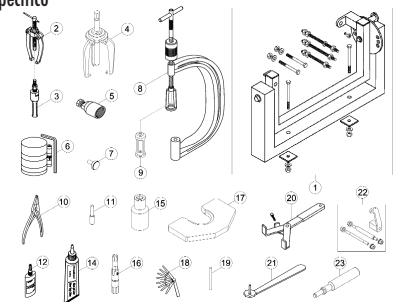

TAV.17 Telaio - Frame - Chassis - Rahmen - Chasis

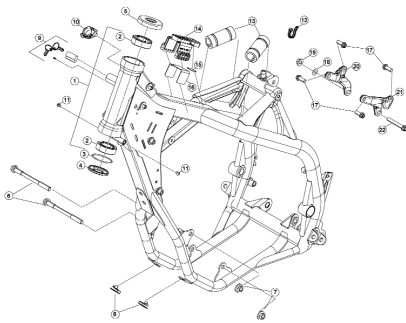

TAV.18 Accessori telaio - Frame accessories - Accessoires chassis - Rahmenezubehören - Accesorios Chasis

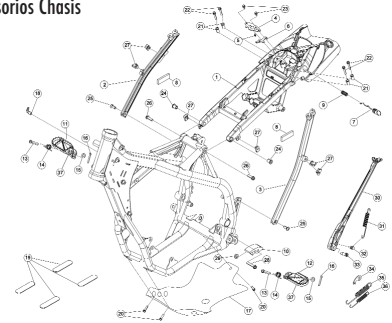

TAV.19 Forcellone posteriore - Rear fork - Fourche arriere - Hinterradschwinge - Horquilla posterior

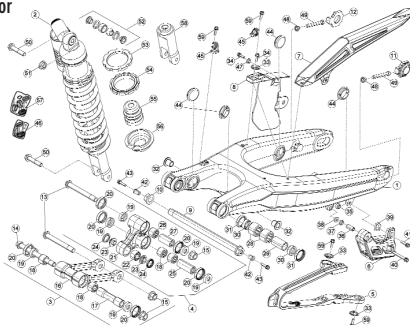

TAV.20 Forcella anteriore - Front fork - Fourche AV. - Vorderradgabel - Horquilla delantera

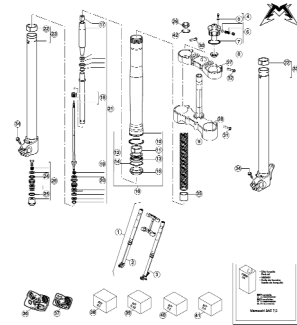

TAV.20A Forcella anteriore - Front fork - Fourche AV. - Vorderradgabel - Horquilla delantera

FACTORY

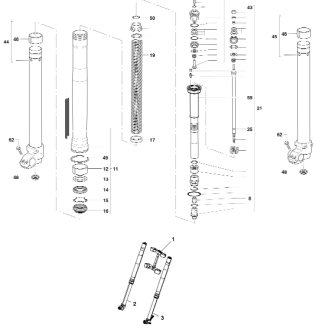

TAV.21 Comandi-Manubrio - Controls-Handlebars - Commandes-Guidon - Bedienungselemente-Lenker - Mandos-Manillar

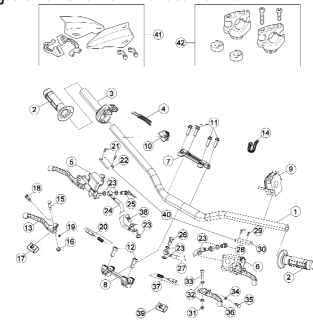

TAV.22 Impianto freni idraulici - Hydraulic brakes system - Installation des freins hydrauliques - Hidraulischebremse anlage - Instalación freno hidráulico

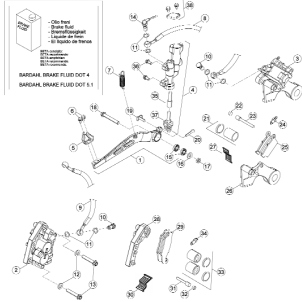

TAV.23 Gruppo scarico - Exhaust system - Echappement - Auspuffanlage - Grupo escape

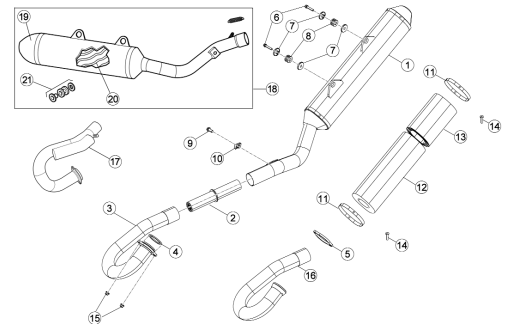

TAV.24 Scatola filtro - Filter box - Boîtier du filtre - Sicherungskasten - Caja del filtro

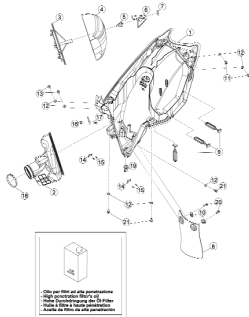

TAV.25 Impianto di raffreddamento - Installation de refroidissement - Installation de refroidissement - Kühlsystem - Instalación de enfriamiento

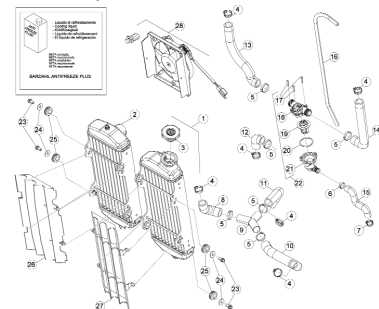

TAV.26 Impianto elettrico - Electrical equipment - Installation électrique - Elektrische anlage - Instalación eléctrica

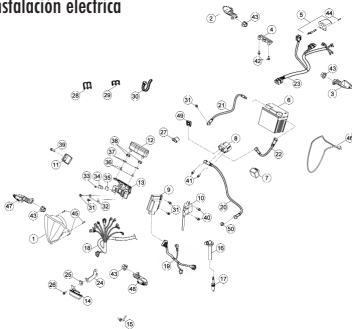

TAV.27 Ruota anteriore - Front wheel - Roue AV. - Vorderrad - Rueda delantera

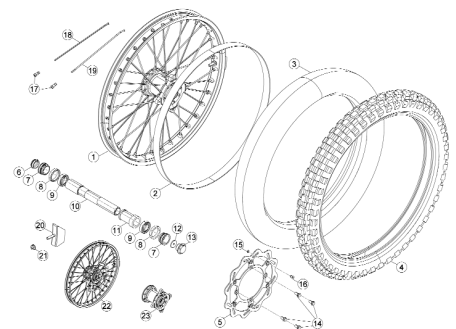

TAV.28 Ruota posteriore - Rear wheel - Roue AR. - Hinterrad - Rueda trasera

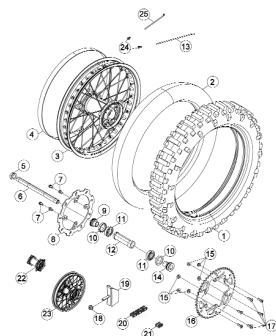

TAV.29 Carenature-Serbatoio-Sella - Fairings-Tank-Saddle - Carenages-Reservoir-Selle - Verkleidungen-Tank-Sattel - Carenados-Deposito-Sillin

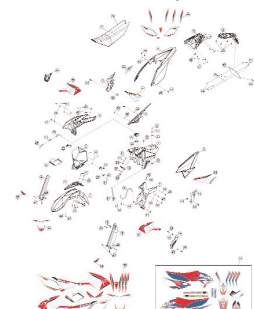

TAV.30 Attrezzatura specifica - Special tools - Outillage spécial - Spezialwerkzeug -  
Utillaje específico



# Tav.1

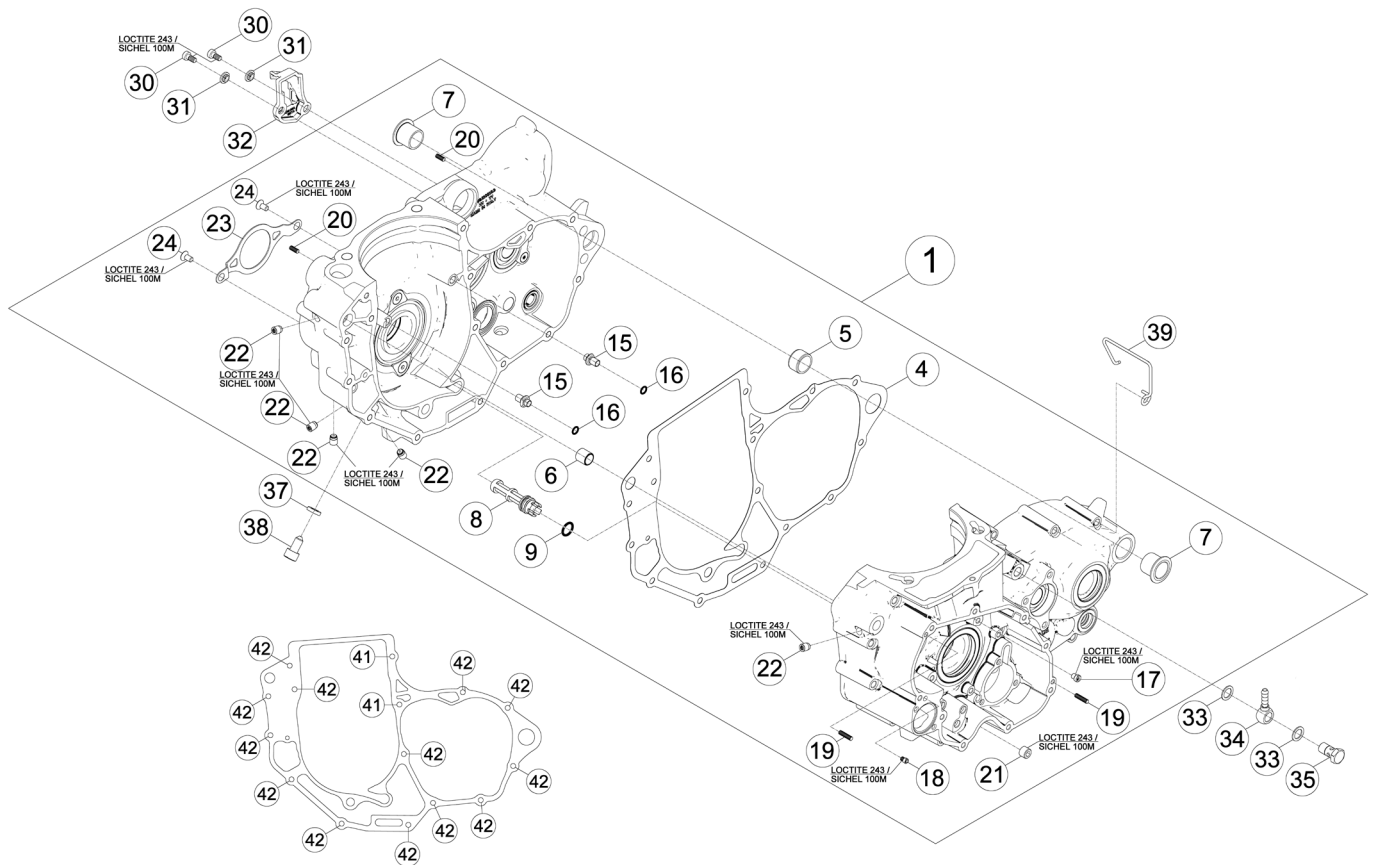

# Tav.1

Pos Loc Pos Ps Pos	Numero Number Número Nummer	Q.ità Q.ty Q.té M.ge C.ad	Nota Note Note Nota Anm.	Descrizione	Description	Désignation	Beschreibung	Descrìption
1	022010008 000	1	350	Carter motore completo	Crankcase assy.	Carter moteru complet	Kurbekgehäuse, kompl.	Carter motor completo
1	006011008 000	1	400-450 520	Carter motore completo	Crankcase assy.	Carter moteru complet	Kurbekgehäuse, kompl.	Carter motor completo
4	006010030 000	1		Guarnizione Carter Motore	Crankcase Gasket	Joint Carter Moteur 4t	Motorgehäusedichtung	Junta Carter Motor
5	006010120 000	1		Grano di riferimento 17x21.12	Dowel 17x21.12	Repère 17x21.12	Passtift 17x21.12	Centraje 17x21.12
6	1641500 000	1		Grano di riferimento	Dowel	Repère	Passtift	Centraje
7	006010110 000	2		Boccola 17X21X19	Bush 17X21X19	Moyeu 17X21X19	Büchse 17X21X19	Buje 17X21X19
8	006080538 000	1		Filtro olio	Oil filter	Filtre à huile	Ölfiter	Filtro de aceite
9	1050010 000	1		Anello OR 8x1,5x	O-Ring 8x1,5x	Bague d'étanchéité 8x1,5x	O-Ring 8x1,5x	Anillo OR 8x1,5x
15	006010240 000	2		Getto olio raffreddamento	Cooling oil jet	Gicleur huile de refr.	Öldüse	Surtidor aceite de enfr.
16	1066139 000	2		Anello OR 6 x 1,5	O-Ring 6 x 1,5	Bague d'étanchéité 6 x 1,5	O-Ring 6 x 1,5	Anillo OR 6 x 1,5
17	1642903 000	1		Getto lubrificazione 100	Lubrication jet 100	Gliceur lubrification 100	Düse Schmierung 100	Surtidor lubricación 100
18	1642904 000	1		Getto lubrificazione carter 100	Lubrication jet crankcase 100	Gliceur lubrification carter 100	Düse Schmierung Kurbelwellengehäuse 100	Surtidor lubricación cárter 100
19	1293384 000	2		Rullino 4x15,8	Roller 4x15,8	Rouleau 4x15,8	Rolle 4x15,8	Rodillo 4x15,8
20	3625021 000	2		Rullino 4,0 X 9,8	Roller 4,0 X 9,8	Rouleau 4,0 X 9,8	Rolle 4,0 X 9,8	Rodillo 4,0 X 9,8
21	3165630 000	1		Vite M10X10	Screw M10X10	Vis M10X10	Schraube M10X10	Tornillo M10X10
22	006010210 000	5		Tappo olio ad espansione 7X9	Oil expansion plug 7X9	Bouchon d'huile à expansion 7X9	Öl-expansionsstopfen 7X9	Tapón extensible del aceite 7X9
23	006010180 009	1		Piastrina	Plate	Plaque	Plättchen	Placa
24	3130085 000	7		Vite M5X10	Screw M5X10	Vis M5X10	Schraube M5X10	Tornillo M5X10
30	3129823 000	2		Vite M5X10	Screw M5X10	Vis M5X10	Schraube M5X10	Tornillo M5X10
31	006080810 000	2		Boccola	Bush	Moyeu	Büchse	Buje
32	022080808 000	1		Rampa olio	Oil incline	Rampe huile	Ölrampe	Diffusor aceite
33	1650510 000	2		Guarnizione 10x15x1 in rame	Gasket 10x15x1 copper	Joint 10x15x1 cuivre	Dichtung 10x15x1 Kupfer	Junta 10.15.1 (cobre)
34	2723476 000	1		Raccordo sfiato	Breather pipe	Raccord pour vidange	Entlüftungsrohranschluß	Racor ventilación
35	1165040 000	1		Bullone forato 10x1 x tubo freno	Special bolt	Boulon 10x1 x tube frein	Hohlschraube F.Bremse	Tornillo esp. talad.10.1
37	006010260 000	1		Rondella in rame 8x14.3	Copper washer 8x14.3	Rondelle en cuivre 8x14.3	Kupfer U.Scheibe 8x14.3	Arandela de cobre 8x14.3
38	006010250 000	1		Vite di centraggio M8X16x	Centering screw M8X16x	Vis de centrage M8X16x	Zentrierschraube M8X16x	Tornillo de centraje M8X16x
39	006010230 000	1		Passacavo	Grommet	Passe-câble	Kabeldurchgang	Pasacables
41	3625013 000	2		Bullone M6x75	Bolt M6x75	Boulon M6x75	Bolzen M6x75	Tornillo M6x75
42	1150585 000	13		Bullone M6x65	Bolt M6x65	Boulon M6x65	Bolzen M6x65	Tornillo M6x65

# Tav.2

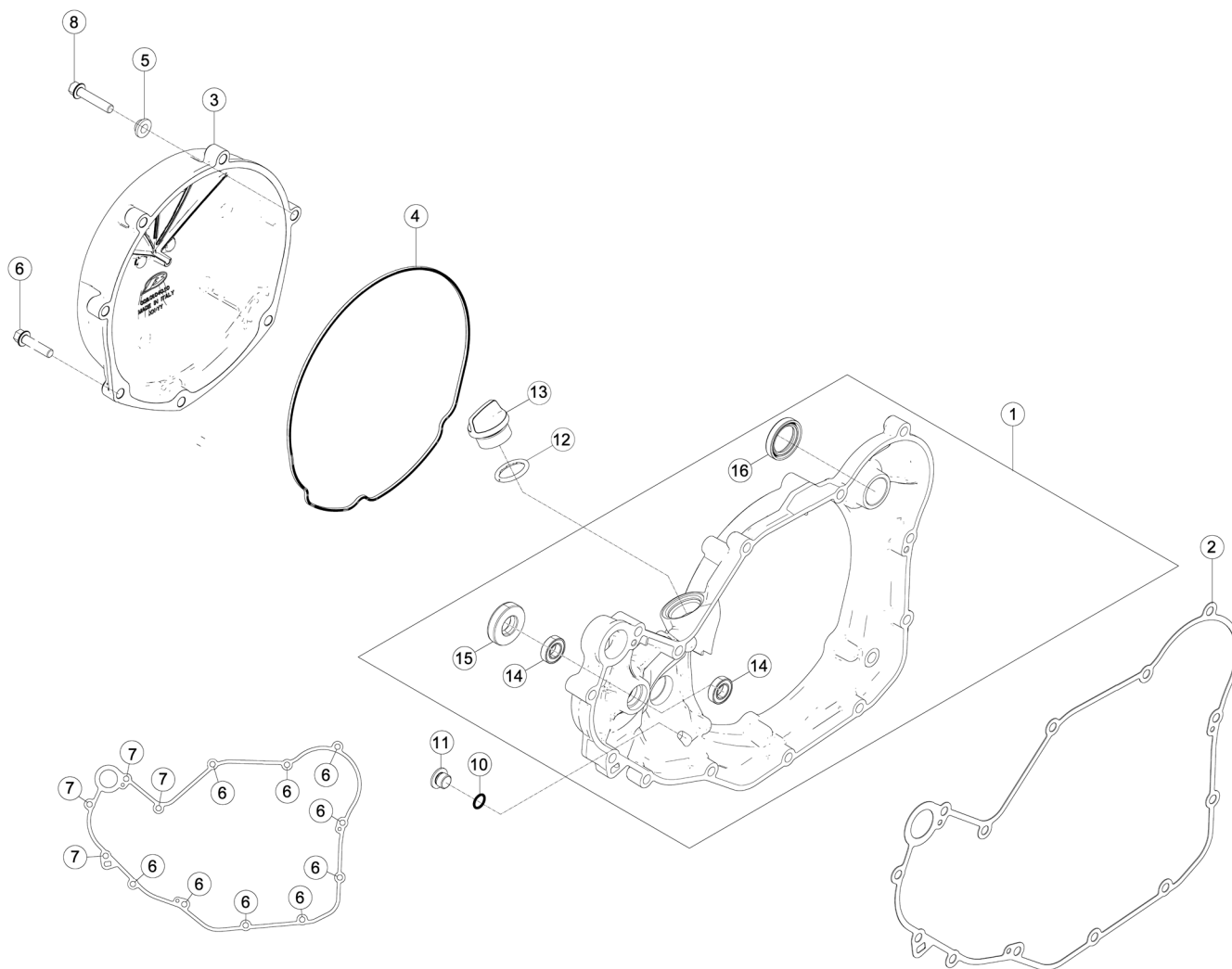

Pos Loc Ps Pos	Numero Number Numéro Número Nummer	Q.tà Q.ty Q.té M.ge C.ad	Nota Note Note Nota Anm.	Descrizione	Description	Désignation	Beschreibung	Descripció
1	006010308 000	1		Coperchio frizione interno	Inner clutch cover	Couvercle interne d'embrayage	Innerer Kupplungsdeckel	Tapa interior embrague
2	006010310 000	1		Guarnizione coperchio frizione	Clutch cover gasket	Joint couvercle embrayage	Dichtung Kupplungsabdeckung	Junta tapa embrague
3	006010400 052	1		Coperchio frizione esterno	Outer clutch cover	Couvercle externe d'embrayage	Äußerer Kupplungsdeckel	Tapa exterior embrague
4	006010410 000	1		Guarnizione coperchio frizione	Clutch cover gasket	Joint couvercle embrayage	Dichtung Kupplungsabdeckung	Junta tapa embrague
5	1354820 000	1		Distanziale 6,5x9,0x13,5	Spacer 6,5x9,0x13,5	Entretoise 6,5x9,0x13,5	Distanzstück 6,5x9,0x13,5	Distanciador 6,5x9,0x13,5
6	1150010 000	15		Bullone M6x25	Bolt M6x25	Boulon M6x25	Bolzen M6x25	Tornillo M6x25
7	1150360 000	4		Bullone M6x40	Bolt M6x40	Boulon M6x40	Bolzen M6x40	Tornillo M6x40
8	1150300 000	1		Bullone 6x30 ch rs	Bolt 6x30 ch rs	Boulon 6x30 ch rs	Bolzen 6x30 ch rs	Tornillo 6x30 ch rs
10	1050010 000	1		Anello OR 8x1,5x	O-Ring 8x1,5x	Bague d'étanchéité 8x1,5x	O-Ring 8x1,5x	Anillo OR 8x1,5x
11	006110450 000	1		Tappo Albero coperchio frizione	Clutch cover Arm Plug	Bouchon Arbre	Endkappe Kupplungsdeckel	Tapa Ciguenal embrague
11	006150060 000	1	FACTORY	Tappo Albero coperchio frizione	Clutch cover Arm Plug	Couvercle d'embrayage Bouchon Arbre	Endkappe Kupplungsdeckel	Tapa Ciguenal embrague
12	1066340 000	1		Anello OR 16x3	O-Ring 16x3	Bague d'étanchéité 16x3	O-Ring 16x3	Anillo OR 16x3
13	2909601 000	1		Tappo carico olio	Oil filling cap	Bouchon rempl. huile	Öleinfüllstöpsel	Tapón intruducción aceite
13	2909601 053	1	FACTORY	Tappo carico olio	Oil filling cap	Bouchon rempl. huile	Öleinfüllstöpsel	Tapón intruducción aceite
14	1293400 000	2		Cuscinetto 10x19.5	Bearing 10x19.5	Roulement 10x19.5	Lager 10x19.5	Cojinete 10x19.5
15	1048030 000	1		Anello paraolio 12x30.7	Oil seal 12x30.7	Joint d'étanchéité 12x30.7	Ölschutzring 12x30.7	Retén de aceite 12x30.7
16	1064490 000	1		Anello paraolio 20x30.5/6	Oil seal 20x30.5/6	Joint d'étanchéité 20x30.5/6	Ölschutzring 20x30.5/6	Retén de aceite 20x30.5/6





# Tav.3

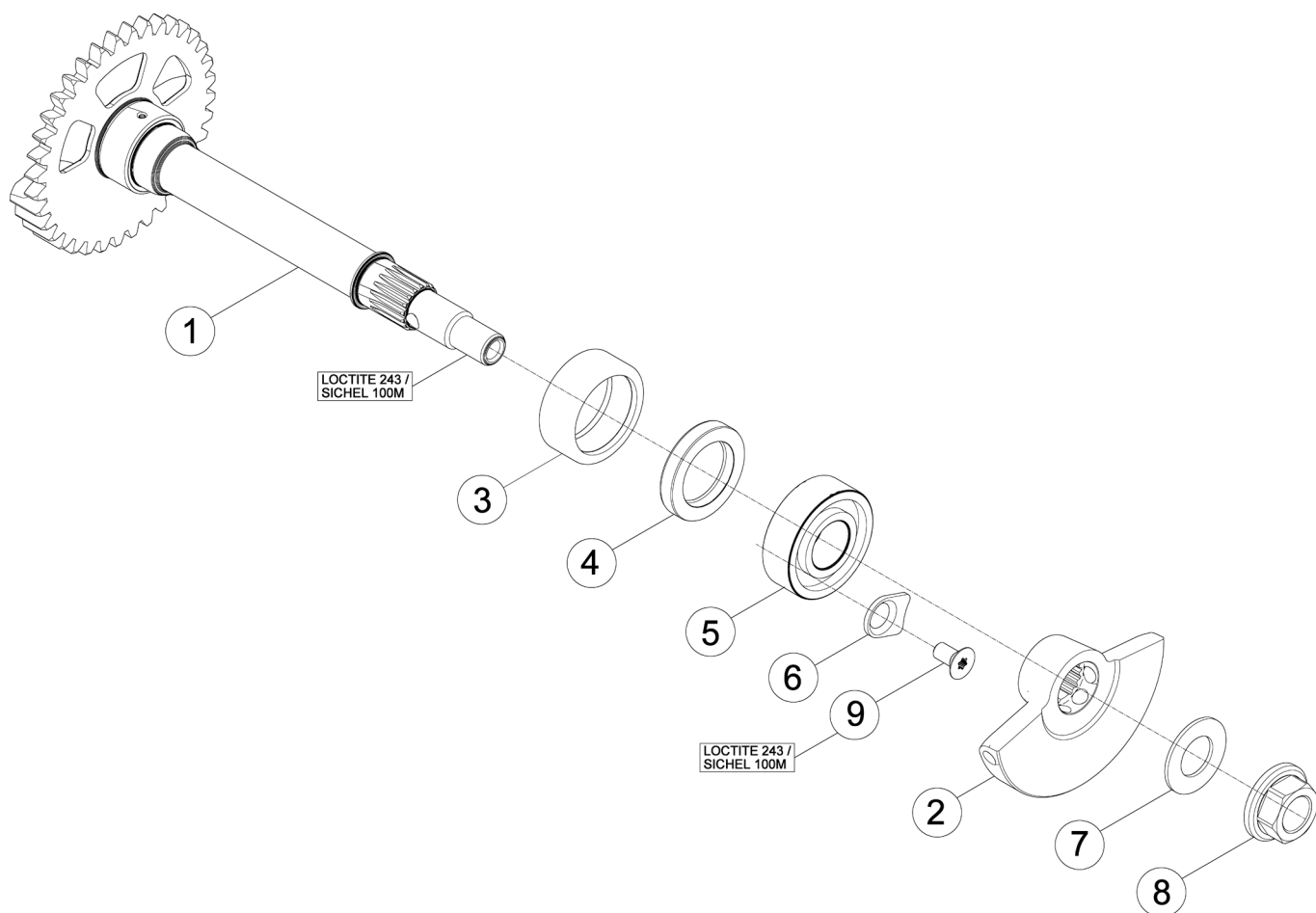

Pos Loc Pos Ps Pos	Numero Number Numéro Número Nummer	Q.tà Q.ty Q.té M.ge C.ad	Nota Note Note Nota Anm.	Descrizione	Description	Désignation	Beschreibung	Descripcìon
1	006021200 000	1	350	Albero Bilanciamento	Balancer Shaft	Arbre Equilibrage	Ausgleichswelle	Árbol Equilibrado
1	006020200 000	1	400-450 520	Albero Bilanciamento	Balancer Shaft	Arbre Equilibrage	Ausgleichswelle	Árbol Equilibrado
2	006020210 000	1		Contrappeso	Counter weight	Contrepoids	Gegengewicht	Contrapeso
3	1123310 000	1	350	Boccola a rulli 25x32.16	Roller bearing 25x32.16	Douille à roulements 25x32.16	Rollenbuchse 25x32.16	Caja de grasa de rodillos 25x32.16
3	1123300 000	1	400-450 520	Boccola a rulli 25x32.12	Roller bearing 25x32.12	Douille à roulements 25x32.12	Rollenbuchse 25x32.12	Caja de grasa de rodillos 25x32.12
4	1064490 000	1		Anello paraolio 20x30.5/6	Oil seal 20x30.5/6	Joint d'étanchéité 20x30.5/6	Ölschutzring 20x30.5/6	Retén de aceite 20x30.5/6
5	1294005 000	1		Cuscinetto 15x35.11	Bearing 15x35.11	Roulement 15x35.11	Lager 15x35.11	Cojinete 15x35.11
6	006010190 009	1		Piastrina	Plate	Plaque	Plättchen	Placa
7	2774810 000	1		Rondella elastica	Spring Washer	Rondelle élastique	Federring	Arandela elástica
8	1325010 000	1		Dado M12x1	Nut M12x1	Ecrou M12x1	Mutter M12x1	Tuerca M12x1
9	3130085 000	1		Vite M5X10	Screw M5X10	Vis M5X10	Schraube M5X10	Tornillo M5X10

# Tav.4

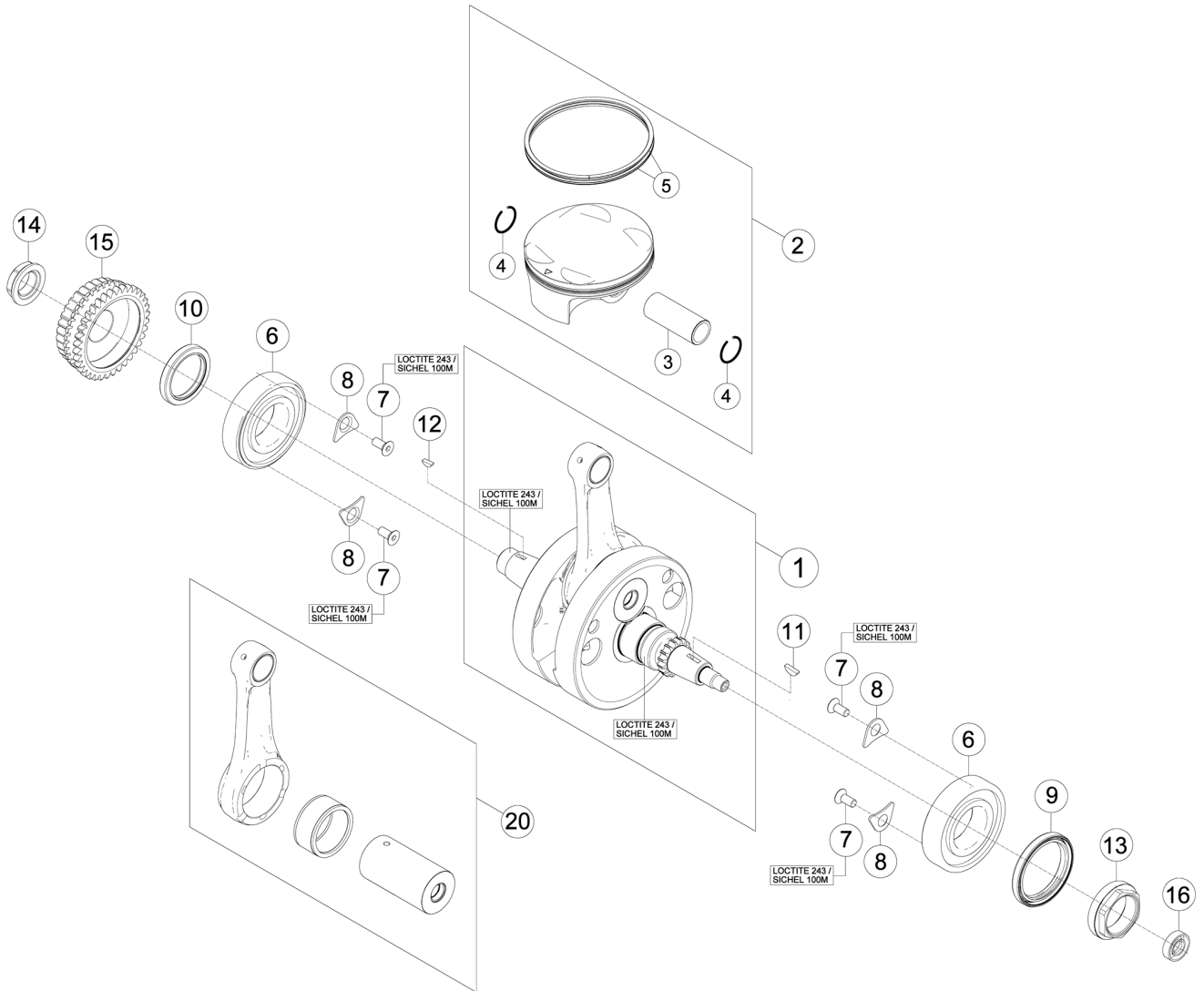

# Tav.4

Pos Loc Pos Ps Pos	Numero Number Numéro Número Nummer	Q.tà Q.ty Q.té M.ge C.ad	Nota Note Note Nota Anm.	Descrizione	Description	Désignation	Beschreibung	Descripcìon
1	022020008 000	1	350	Albero motore completo	Crankshaft, assy.	Arbre moteur complet	kurbelwelle, komplett	Cigüeñal completo
1	006023008 000	1	400	Albero motore completo	Crankshaft, assy.	Arbre moteur complet	kurbelwelle, komplett	Cigüeñal completo
1	006024008 000	1	450-520	Albero motore completo	Crankshaft, assy.	Arbre moteur complet	kurbelwelle, komplett	Cigüeñal completo
2	022020508 001	1	350	Pistone completo misura 1	Piston set size 1	Piston compl. taille 1	Kolben, kompl. ausmessen 1	Pistón, compl. mensura 1
2	006025508 001	1	400	Pistone completo misura 1	Piston set size 1	Piston compl. taille 1	Kolben, kompl. ausmessen 1	Pistón, compl. mensura 1
2	006023508 001	1	450	Pistone completo misura 1	Piston set size 1	Piston compl. taille 1	Kolben, kompl. ausmessen 1	Pistón, compl. mensura 1
2	006024508 001	1	520	Pistone completo misura 1	Piston set size 1	Piston compl. taille 1	Kolben, kompl. ausmessen 1	Pistón, compl. mensura 1
2	022020508 002	1	350	Pistone completo misura 2	Piston set size 2	Piston compl. taille 2	Kolben, kompl. ausmessen 2	Pistón, compl. mensura 2
2	006025508 002	1	400	Pistone completo misura 2	Piston set size 2	Piston compl. taille 2	Kolben, kompl. ausmessen 2	Pistón, compl. mensura 2
2	006023508 002	1	450	Pistone completo misura 2	Piston set size 2	Piston compl. taille 2	Kolben, kompl. ausmessen 2	Pistón, compl. mensura 2
2	006024508 002	1	520	Pistone completo misura 2	Piston set size 2	Piston compl. taille 2	Kolben, kompl. ausmessen 2	Pistón, compl. mensura 2
3	022020510 000	1	350	Spinotto	Pin	Axe	Zapfen	Eje
3	006020510 000	1	400-450	Spinotto	Pin	Axe	Zapfen	Eje
4	022020520 000	2	350	Anello ferma spinotto	Piston pin lock ring	Bague de serrage goujon	Bolzenfeststerring	Anillo sujeta pasador
4	006021520 000	2	400-450	Anello ferma spinotto	Piston pin lock ring	Bague de serrage goujon	Bolzenfeststerring	Anillo sujeta pasador
5	022020538 000	1	350	Segmenti pistone D=88MM	Piston rings D=88MM	Segments de piston D=88MM	Kolbendichtring D=88MM	Aros piston D=88MM
5	006020538 000	1	400-450	Segmenti pistone D=95MM	Piston rings D=95MM	Segments de piston D=95MM	Kolbendichtring D=95MM	Aros piston D=95MM
5	006021538 000	1	520	Segmenti pistone D=100MM	Piston rings D=100MM	Segments de piston D=100MM	Kolbendichtring D=100MM	Aros piston D=100MM
6	1299700 000	2		Cuscinetto 35x72	Bearing 35x72	Roulement 35x72	Lager 35x72	Cojinete 35x72
7	3130474 000	4		Vite M6X14	Screw M6X14	Vis M6X14	Schraube M6X14	Tornillo M6X14
8	006010160 000	4		Piastrina	Plate	Plaquette	Plättchen	Placa
9	1066085 000	1		Anello paraolio 45x58.7	Oil seal 45x58.7	Joint d'étanchéité 45x58.7	Ölschutzring 45x58.7	Retén de aceite 45x58.7
10	1065900 000	1		Anello paraolio 35x47.6	Oil seal 35x47.6	Joint d'étanchéité 35x47.6	Ölschutzring 35x47.6	Retén de aceite 35x47.6
11	1246020 000	1		Chiavetta 3x5	Key 3x5	Clavette 3x5	Keil 3x5	Chaveta 3x5
12	1246000 000	1		Chiavetta	Key	Clavette	Keil	Chaveta
13	022020110 000	1		Dado M32X1	Nut M32X1	Ecrou M32X1	Mutter M32X1	Tuerca M32X1
14	006030230 000	1		Dado M20X1x5 LH	Nut M20X1x5 LH	Ecrou M20X1x5 LH	Mutter M20X1x5 LH	Tuerca M20X1x5 LH
15	022030218 000	1	350	Pignone	Pinion	Pignon	Ritzel	Piñón
15	006031218 000	1	400-450	Pignone	Pinion	Pignon	Ritzel	Piñón
16	1044690 000	1		Anello paraolio 10x22.6	Oil seal 10x22.6	Joint d'étanchéité 10x22.6	Ölschutzring 10x22.6	Retén de aceite 10x22.6
20	022020088 000	1	350	Biella completa	Conn.-rod, assy	Bielle compl.	Plevel, kompl.	Biella compl.
20	006021088 000	1	400-450	Biella completa	Conn.-rod, assy	Bielle compl.	Plevel, kompl.	Biella compl.

## FACTORY

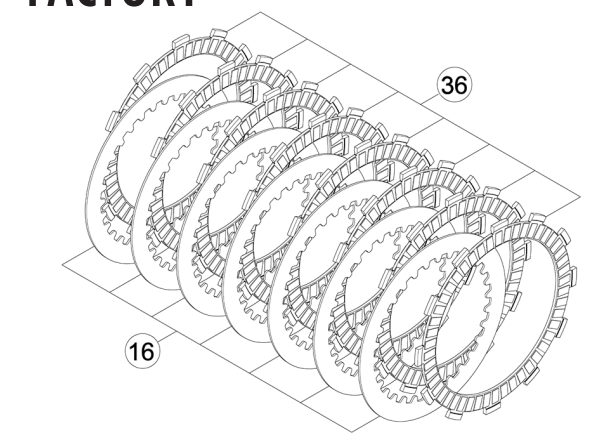

## STANDARD

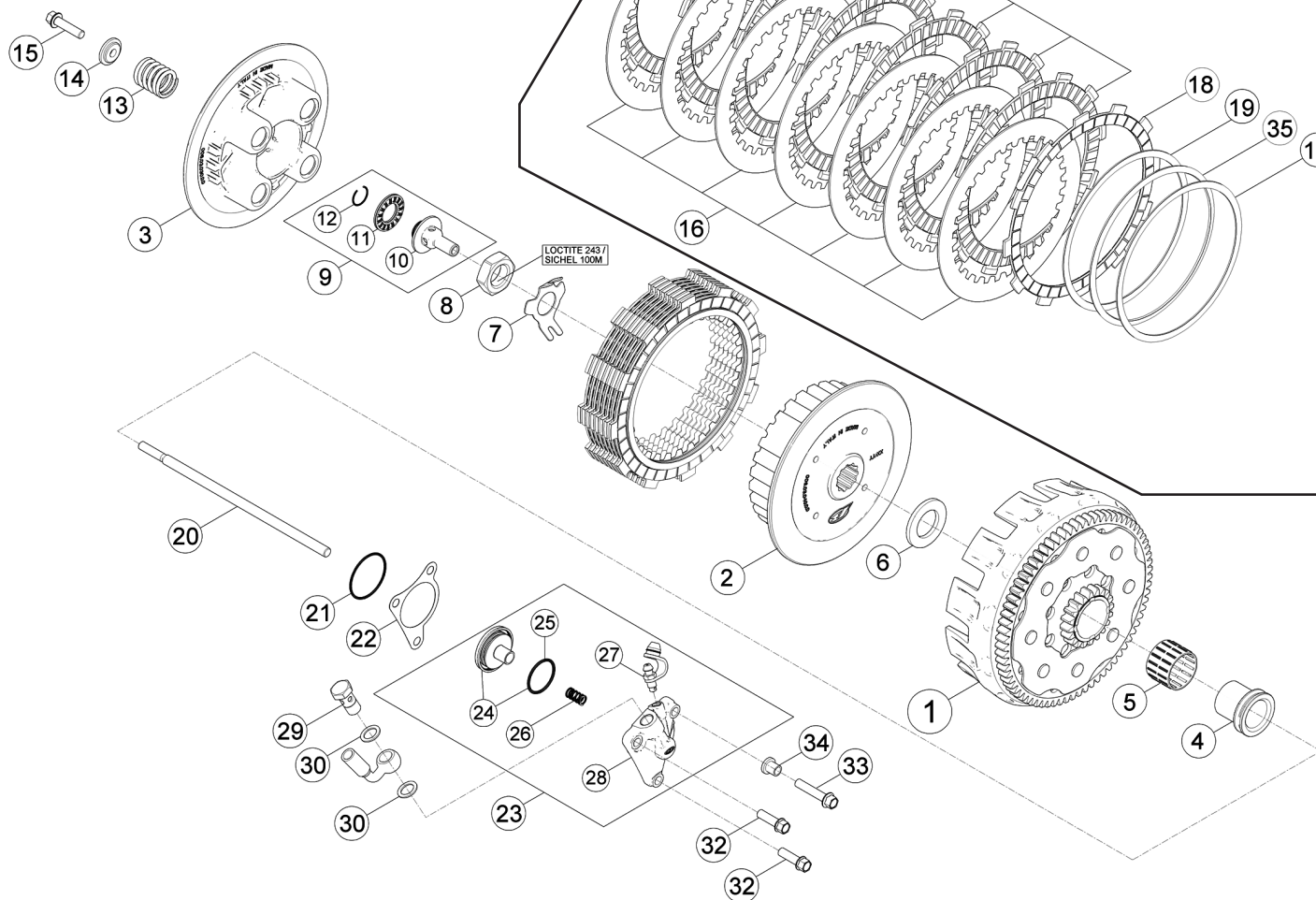
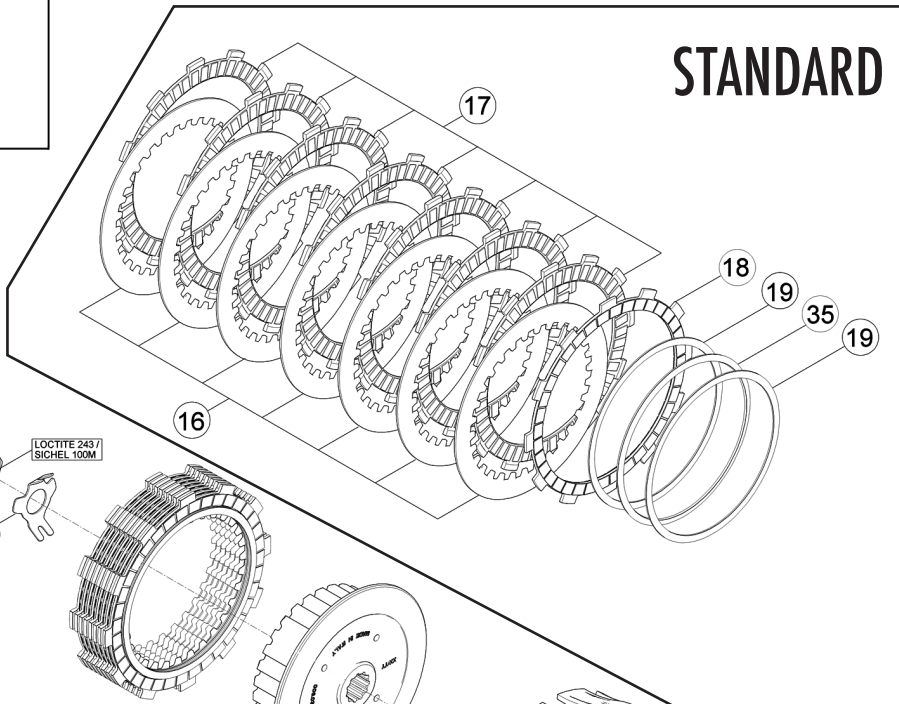

# Tav.5

Pos Loc Pos Ps Pos	Numero Number Numéro Número Nummer	Q.tà Q.ty Q.té M.ge C.ad	Nota Note Note Nota Anm.	Descrizione	Description	Désignation	Beschreibung	Descripción
1	022030118 000	1	350	Campana frizione	Clutch case	Cloche d'embrayage	Kupplungsglocke	Campana de embr.
1	006031118 000	1	400-450 520	Campana frizione	Clutch case	Cloche d'embrayage	Kupplungsglocke	Campana de embr.
2	006031400 000	1		Tamburo frizione	Clutch drum	Tambour d'embr.	Kupplungstrommel	Tambor de embr.
3	006030300 000	1		Piattello spingidisco	Spring collar	Godet d'embrayage	Druckteller	Platillo embrague
4	006030610 000	1		Boccola	Bush	Moyeu	Büchse	Buje
5	006030630 000	1		Boccola a rulli 26x30.22.	Roller bearing 26x30.22.	Douille à roulements 26x30.22.	Rollenbuchse 26x30.22.	Caja de grasa de rodillos 26x30.22.
6	006030620 000	1		Rondella 21,7x38.3.	Washer 21,7x38.3.	Rondelle 21,7x38.3.	U.Scheibe 21,7x38.3.	Arandela 21,7x38.3.
7	006030640 009	1		Rondella di sicurezza	Tab washer	Rondelle de sûreté	Sicherungs-Unterlegscheibe	Arandela de seguridad
8	006030650 000	1		Dado M18x1,5 h9	Nut M18x1,5 h9	Ecrou M18x1,5 h9	Mutter M18x1,5 h9	Tuerca M18x1,5 h9
9	006030718 000	1		Innesto Asta Corpo Frizione comp.	Clutch Housing Rod Coupling, assy	Crabot Tige Corps Embrayage compl.	Stabeinkupplung Kupplungskörper, kpl.	Acople Varilla Cuerpo Embrague comp.
10	006030710 000	1		Innesto Asta Corpo Frizione	Clutch Housing Rod Coupling	Crabot Tige Corps Embrayage	Stabeinkupplung Kupplungskörper	Acople Varilla Cuerpo Embrague
11	1611370 000	1		Gabbia reggispinta 15x28x2	Thrust bearing cage 15x28x2	Butée à aiguilles 15x28x2	Andruckkäfig 15x28x2	Jaula cojinete de empuje 15x28x2
12	2823105 000	1		Seeger RB14 DIN 7993	Circlip RB14 DIN 7993	Circlip RB14 DIN 7993	Seeger RB14 DIN 7993	Seeger RB14 DIN 7993
13	022030550 000	4		Molla frizione	Clutch spring	Ressort embr.	Kupplg.feder	Muelle embr.
14	006031560 000	4		Reggimolla Frizione	Spring Retainer	Porte-Ressort Embrayage	Federteller	Portamuelle Embrague
15	1150010 000	4		Bullone M6x25	Bolt M6x25	Boulon M6x25	Bolzen M6x25	Tornillo M6x25
16	006030500 000	7		Disco acciaio	Steel plate	Disque lisse	Stahlscheibe	Disco
17	006030520 000	7		Disco frizione	Clutch disk	Disque embr.	Kupplungs-scheib	Disco de embrague
18	006031530 000	1		Disco frizione	Clutch disk	Disque embr.	Kupplungs-scheib	Disco de embrague
19	006030570 000	2		Rondella	Washer	Rondelle	U.Scheibe	Arandela
20	006030700 000	1		Innesto Asta Corpo Frizione	Clutch Housing Rod Coupling	Crabot Tige Corps Embrayage	Stabeinkupplung Kupplungskörper	Acople Varilla Cuerpo Embrague
21	1066840 000	1		Anello OR 33x1,5	O-Ring 33x1,5	Bague d'étanchéité 33x1,5	O-Ring 33x1,5	Anillo OR 33x1,5
22	006030850 000	1		Guarnizione frizione	Clutch lining	Garniture embrayage	Kupplungsbelag	Forro de embrague
23	006030808 000	1		Corpo attuatore	Actuator body	Corps actionneur	Gehäuse Stellantrieb	Cuerpo del actuador
24	006030818 000	1		Pistone	Piston	Piston	Kolben	Pistón
25	1066520 000	1		Anello OR 23,52X1,78	O-Ring 23,52X1,78	Bague d'étanchéité 23,52X1,78	O-Ring 23,52X1,78	Anillo OR 23,52X1,78
26	006030830 000	1		Molla	Spring	Ressort	Feder	Muelle
27	2891050 800	1		Sfiato aria	Bleed nipple	Purge d'air	Entlüftungsnippel	Respiradero
28	006030800 000	1		Corpo attuatore	Actuator body	Corps actionneur	Gehäuse Stellantrieb	Cuerpo del actuador
29	1165040 000	1		Bullone forato 10x1 x tubo freno	Special bolt	Boulon 10x1 x tube frein	Hohlschraube F.Bremse	Tornillo esp. talad.10.1
30	1650510 000	2		Guarnizione 10x15x1 in rame	Gasket 10x15x1 copper	Joint 10x15x1 cuivre	Dichtung 10x15x1 Kupfer	Junta 10.15.1 (cobre)
32	1149070 000	2		Bullone 6x20 ch rs	Bolt 6x20 ch rs	Boulon 6x20 ch rs	Bolzen 6x20 ch rs	Tornillo 6x20 ch rs
33	1150300 000	1		Bullone 6x30 ch rs	Bolt 6x30 ch rs	Boulon 6x30 ch rs	Bolzen 6x30 ch rs	Tornillo 6x30 ch rs
34	1349189 000	1		Distanziale	Spacer	Entretoise	Distanzstück	Distanciator
35	006030580 000	1		Molla a tazza	Belleville spring	Ressort à godet	Tassenfeder	Muelle de taza
36	006030520 000	8	FACTORY	Disco frizione	Clutch disk	Disque embr.	Kupplungs-scheib	Disco de embrague

# Tav.6

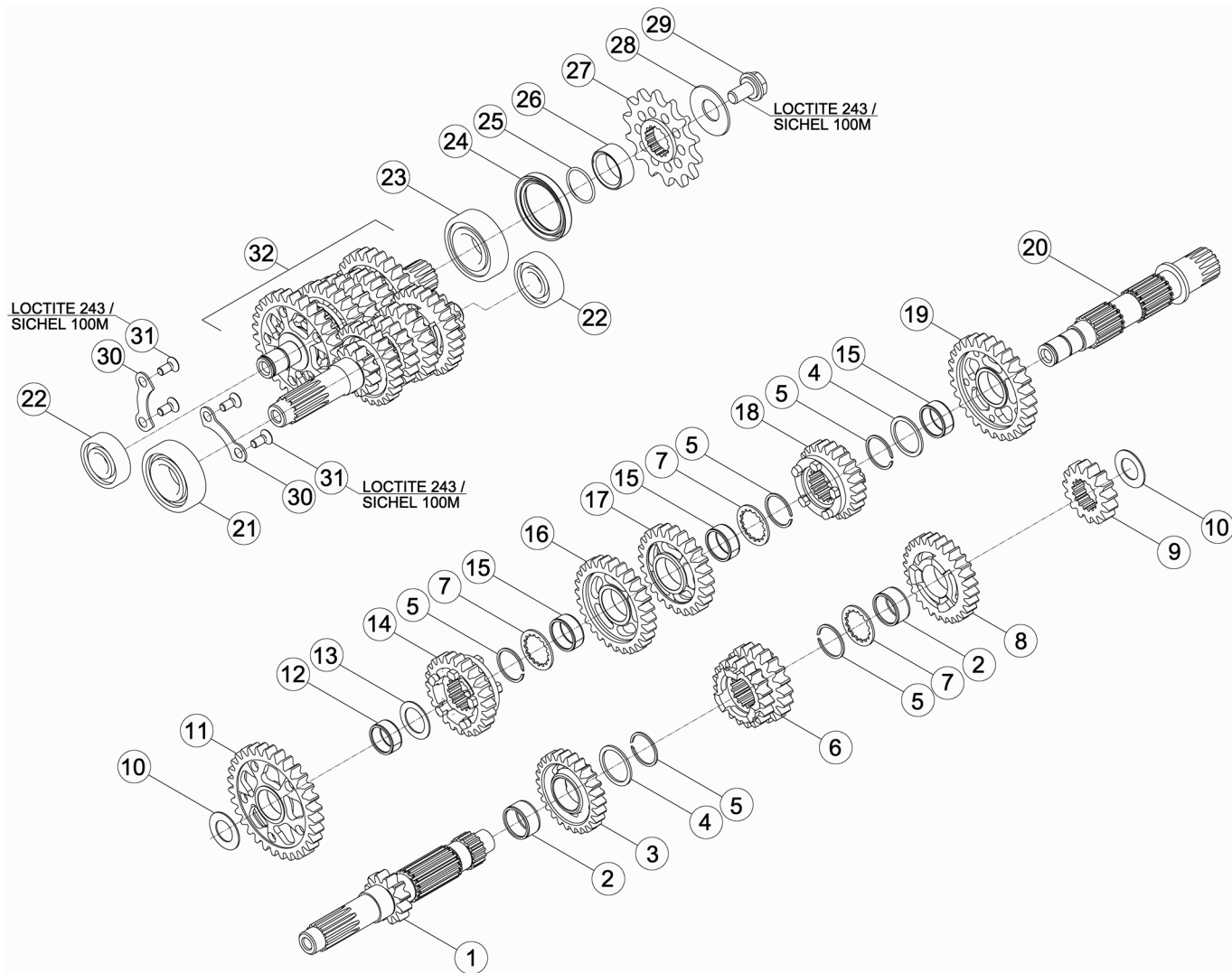

# Tav.6

Pos Loc Pos Ps Pos	Numero Number Numéro Número Nummer	Q.tà Q.ty Q.té M.ge C.ad	Nota Note Note Nota Anm.	Descrizione	Description	Désignation	Beschreibung	Descripcìon
1	006040100 000	1		Albero primario	Mainshaft	Arbre primaire	Hauptwelle	Arbol primario
2	1122855 000	2		Gabbia a rulli 22x26x13	Roller cage 22x26x13	Cage a roul. 22x26x13	Rollenkäfig 22x26x13	Jaula de rod. 22x26x13
3	006040150 000	1		Quinta sul primario	Fifth gear - mainshaft	Cinquième sur le primaire	5. Gang auf antriebswelle	Quinta marcha en el cigüeñal primario
4	006040310 000	2		Rondella rasamento	Thrust washer	Rondelle de butée	Anlaufscheibe	Arandela distanciadora
5	2825520 000	5		Seeger SW25	Circlip SW25	Circlip SW25	Seeger SW25	Seeger SW25
6	006040130 000	1		Terza e quarta sul primario	Third and fourth gear - mainshaft	Troisième et quatrième sur le primaire	3. Gang und 4. Gang auf antriebswelle	Tercera y Cuarta marcha en el cigüeñal primario
7	006040300 000	3		Rondella rasamento	Thrust washer	Rondelle de butée	Anlaufscheibe	Arandela distanciadora
8	006040160 000	1		Sesta sul primario	6th gear - mainshaft	Sixième sur le primaire	6. Gang auf antriebswelle	Sexta marcha en el cigüeñal primario
9	006040120 000	1		Seconda sul primario	Second gear - mainshaft	Deuxième sur le primaire	2. Gang auf abtriebswelle	Segunda marcha en el cigüeñal primario
10	006040320 000	2		Rondella rasamento 17x30x1	Thrust washer 17x30x1	Rondelle de butée 17x30x1	Anlaufscheibe 17x30x1	Arandela distanciadora 17x30x1
11	006040210 000	1		Prima sul secondario	First gear - layshaft	Première sur le secondaire	1. Gang auf Vorgelegewelle	Primera marcha en el cigüeñal secundario
12	1122835 000	1		Gabbia a rulli 20x24x10	Roller cage 20x24x10	Cage a roul. 20x24x10	Rollenkäfig 20x24x10	Jaula de rod. 20x24x10
13	006040330 000	1		Rondella rasamento 20x30x1	Thrust washer 20x30x1	Rondelle de butée 20x30x1	Anlaufscheibe 20x30x1	Arandela distanciadora 20x30x1
14	006040250 000	1		Quinta sul secondario	Fifth gear - layshaft	Cinquième sur le secondaire	5. Gang auf Vorgelegewelle	Quinta marcha en el cigüeñal secundario
15	1122845 000	3		Gabbia a rulli 22x26x10	Roller cage 22x26x10	Cage a roul. 22x26x10	Rollenkäfig 22x26x10	Jaula de rod. 22x26x10
16	006040230 000	1		Terza sul secondario	Third gear - layshaft	Troisième sur le secondaire	3. Gang auf Vorgelegewelle	Tercera marcha en el cigüeñal secundario
17	006040240 000	1		Quarta sul secondario	Fourth gear - layshaft	Quatrième sur le secondaire	4. Gang auf Vorgelegewelle	Cuarta marcha en el cigüeñal secundario
18	006040260 000	1		Sesta sul secondario	6th gear - layshaft	Sixième sur le secondaire	6. Gang auf Vorgelegewelle	Sexta marcha en el cigüeñal secundario
19	006040220 000	1		Seconda sul secondario	Second gear - layshaft	Deuxième sur le secondaire	2. Gang auf Vorgelegewelle	Segunda marcha en el cigüeñal secundario
20	006040200 000	1		Albero secondario	Counter shaft	Arbre secondaire	Nebengetriebewelle	Eje secundario
21	1295610 000	1		Cuscinetto 6205	Bearing 6205	Roulement 6205	Lager 6205	Cojinete 6205
22	1295605 000	2		Cuscinetto 6203	Bearing 6203	Roulement 6203	Lager 6203	Cojinete 6203
23	1299710 000	1		Cuscinetto NJ205	Bearing NJ205	Roulement NJ205	Lager NJ205	Cojinete NJ205
24	1066020 000	1		Anello paraolio 32x45x6x5	Oil seal 32x45x6x5	Joint d'étanchéité 32x45x6x5	Ölschutzring 32x45x6x5	Retén de aceite 32x45x6x5
25	1066620 000	1		Anello or 25,12x1,78	O-Ring 25,12x1,78	Bague d'étanchéité 25,12x1,78	O-Ring 25,12x1,78	Anillo OR 25,12x1,78
26	006040400 000	1		Distanziale	Spacer	Entretoise	Distanzstück	Distanciadador
27	006040500 000	1	Z13	Pignone	Pinion	Pignon	Ritzel	Piñón
27	006040510 000	1	Z14	Pignone	Pinion	Pignon	Ritzel	Piñón
27	006040520 000	1	Z15	Pignone	Pinion	Pignon	Ritzel	Piñón
28	006040410 000	1		Rondella	Washer	Rondelle	U.Scheibe	Arandela
29	006040420 000	1		Vite M10x18	Screw M10x18	Vis M10x18	Schraube M10x18	Tornillo M10x18
30	006010170 009	2		Piastrina	Plate	Plaque	Plättchen	Placa
31	3130085 000	4		Vite MSX10	Screw MSX10	Vis MSX10	Schraube MSX10	Tornillo MSX10
32	006040008 000	1		Cambio completo	Transmission, assy	Boîte de vitesses	Getriebe komplett	Cambio completo

# Tav.7

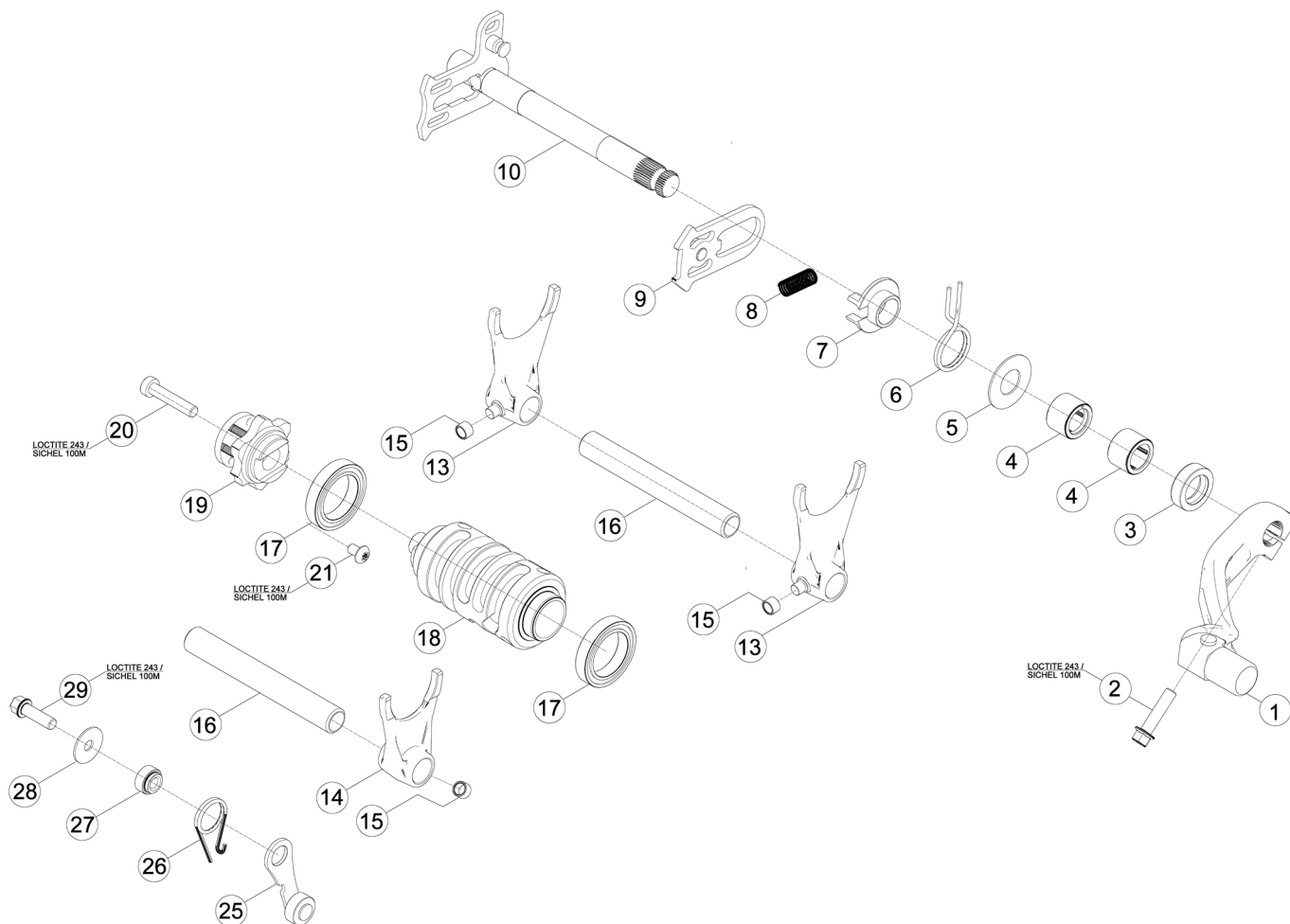



# Tav.7

Pos Loc Pos Ps Pos	Numero Number Numéro Número Nummer	Q.tà Q.ty Q.té M.ge C.ad	Nota Note Note Nota Anm.	Descrizione	Description	Désignation	Beschreibung	Descripcìon
1	006050008 000	1		Leva cambio	Gear change lever	Levier comm. chang. vit.	Schalthebel	Palanca cambio
2	1150010 000	1		Bullone M6x25	Bolt M6x25	Boulon M6x25	Bolzen M6x25	Tornillo M6x25
3	1052012 000	1		Anello paraolio 14x24.6	Oil seal 14x24.6	Joint d'étanchéité 14x24.6	Ölschutzring 14x24.6	Retén de aceite 14x24.6
4	1122320 000	2		Boccola a rulli	Roller bearing	Douille à roulements	Rollenbuchse	Caja de grasa de rodillos
5	2763020 000	1		Rondella rasamento 14x30x1	Thrust washer 14x30x1	Rondelle de butée 14x30x1	Anlaufscheibe 14x30x1	Arandela distanciadora 14x30x1
6	006050170 000	1		Molla ritorno comando cambio	Gearchange return spring	Ressort de retour comm. ch.ge vit.	Rückstellfeder schaltung	Muelle de retorno cambio
7	1692911 000	1		Guida molla	Spring guide	Guide ressort	Federfuehrung	Guia de resorte
8	006050160 000	1		Molla 0,8MM	Spring 0,8MM	Ressort 0,8MM	Feder 0,8MM	Muelle 0,8MM
9	006050148 000	1		Ventaglio mobile	Movable pawl	Eventail mobile	Schaltautomat	Abanico móvil
10	006050118 000	1		Albero comando cambio	Gearshift shaft	Arbre de vitesse	Schaltwelle	Eje mando cambio
13	006050200 000	2		Forchetta 1/4	Fork 1/4	Fourchette 1/4	Schaltgabel 1/4	Horquilla 1/4
14	006050210 000	1		Forchetta 5/6	Fork 5/6	Fourchette 5/6	Schaltgabel 5/6	Horquilla 5/6
15	006050270 000	3		Boccola 6x8.5,2.	Bush 6x8.5,2.	Moyeu 6x8.5,2.	Büchse 6x8.5,2.	Buje 6x8.5,2.
16	006050250 000	2		Perno forchetta	Spindle, fork	Axe de fourche	Schaltgabelstift	Perno de la horquilla
17	1293405 000	2		Cuscinetto 61805	Bearing 61805	Roulement 61805	Lager 61805	Cojinete 61805
18	006050300 000	1		Camma cambio	Selector drum	Barillet de sélection de boîte de vit.	Schaltwalze	Leva de la caja de cambios
19	006050408 000	1		Camma Arresto Marce	Gear Stopper Cam	Came Butée Vitesses	Gangsperrnocken	Leva Parada Marchas
20	3145115 000	1		Vite M6X30	Screw M6X30	Vis M6X30	Schraube M6X30	Tornillo M6X30
21	3130084 000	1		Vite M5X8	Screw M5X8	Vis M5X8	Schraube M5X8	Tornillo M5X8
25	006050508 000	1		Leva arresto marce	Gear stop lever	Levier arrêt vit.	Gangstophebel	Palanca arresto vel.
26	2239590 000	1		Molla arresto marce	Gear stop spring	Ressort arrêt vit.	Gangstopffeder	Muelle arresto vel.
27	006050540 000	1		Distanziale	Spacer	Entretoise	Distanzstück	Distanciador
28	2742000 100	1		Rondella 6x20.1,0	Washer 6x20.1,0	Rondelle 6x20.1,0	U.Scheibe 6x20.1,0	Arandela 6x20.1,0
29	1149070 000	1		Bullone 6x20 ch rs	Bolt 6x20 ch rs	Boulon 6x20 ch rs	Bolzen 6x20 ch rs	Tornillo 6x20 ch rs

# Tav.8

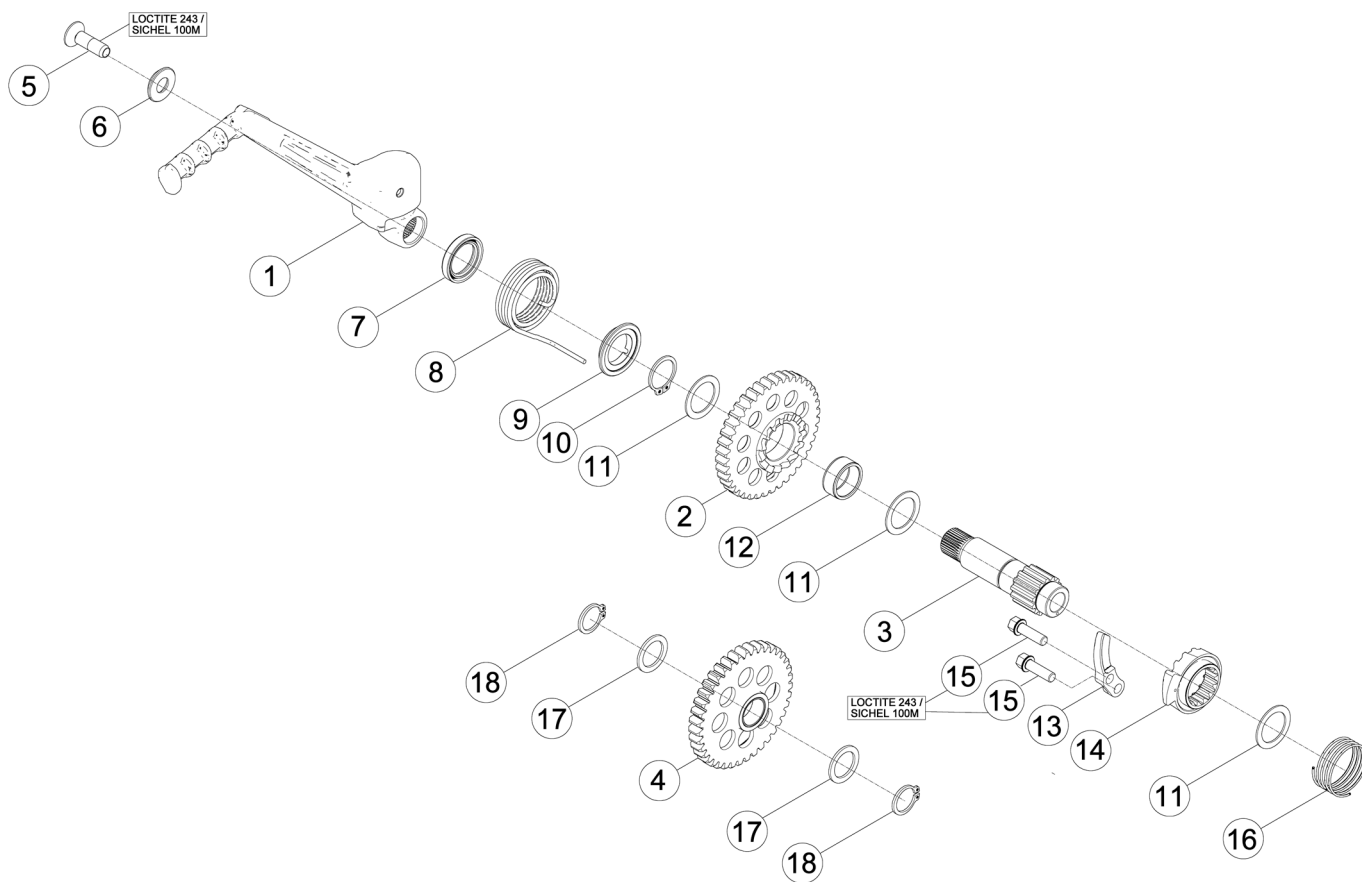

Pos Loc Pos Ps Pos	Numero Number Numéro Número Nummer	Q.tà Q.ty Q.té M.ge C.ad	Nota Note Note Nota Anm.	Descrizione	Description	Désignation	Beschreibung	Descripció
1	006060008 000	1		Leva messa in moto	Start. lever	Lev.du dém.	Kickstarterhebel	Palanca de arranque
2	006060110 000	1	Z.40	Ingranaggio messa in moto	Kickstart gear	Pignon de démarrage	Startergetriebe	Engranaje del arranque
3	006060100 000	1		Albero messa in moto	Kickstarter shaft	Arbre du démarreur	Starterwelle	Eje puesta en marcha
4	006060318 000	1	Z.39	Ingranaggio rinvio m.m.	Kickstart idler gear	Pignon de renvoi de démarr.	Zwischenrad starter	Engr. de reenvio arranque
5	3196827 000	1		Vite speciale M8X26	Special screw M8X26	Vis spéciale M8X26	Spezialschraube M8X26	Tornillo especial M8X26
6	006060080 000	1		Rondella	Washer	Rondelle	U.Scheibe	Arandela
7	1064490 000	1		Anello paraolio 20x30.5/6	Oil seal 20x30.5/6	Joint d'étanchéité 20x30.5/6	Ölschutzring 20x30.5/6	Retén de aceite 20x30.5/6
8	006060130 000	1		Molla richiamo albero messa in moto	Return spring kickstarter shaft	Ressort de rappel arbre du démarreur	Rückzugsfeder Starterwelle	Muelle de retorno eje puesta en marcha
9	006061120 000	1		Distanziale messa in moto	Spacer, kickstart	Entretoise démarrage	Distanzstück starter	Distanciadador del arranque
10	2825400 000	1		Seeger 20e	Circlip 20e	Circlip 20e	Seeger 20e	Seeger 20e
11	2773600 100	3		Rondella spessoramento 20x28.1	Spacer washer 20x28.1	Entretoise 20x28.1	Distanzscheibe 20x28.1	Arandela distanciadora 20x28.1
12	1122835 000	1		Gabbia a rulli 20x24x10	Roller cage 20x24x10	Cage a roul. 20x24x10	Rollenkäfig 20x24x10	Jaula de rod. 20x24x10
13	006060160 000	1		Rampa messa in moto	Kickstart ramp	Rampe de démarrage	Starterrampe	Rampa para el arranque
14	006060140 000	1		Manicotto messa in moto	Kickstart sleeve	Manchon de démarrage	Muffe starter	Manguito arranque
15	1149070 000	2		Bullone 6x20 ch rs	Bolt 6x20 ch rs	Boulon 6x20 ch rs	Bolzen 6x20 ch rs	Tornillo 6x20 ch rs
16	006060150 000	1		Molla	Spring	Ressort	Feder	Muelle
17	2771215 150	2		Rondella 17x24.1,5	Washer 17x24.1,5	Rondelle 17x24.1,5	U.Scheibe 17x24.1,5	Arandela 17x24.1,5
18	2824955 000	2		Seeger 17x1,5	Circlip 17x1,5	Circlip 17x1,5	Seeger 17x1,5	Seeger 17x1,5



**Beta**  
the play bike

# Tav.9

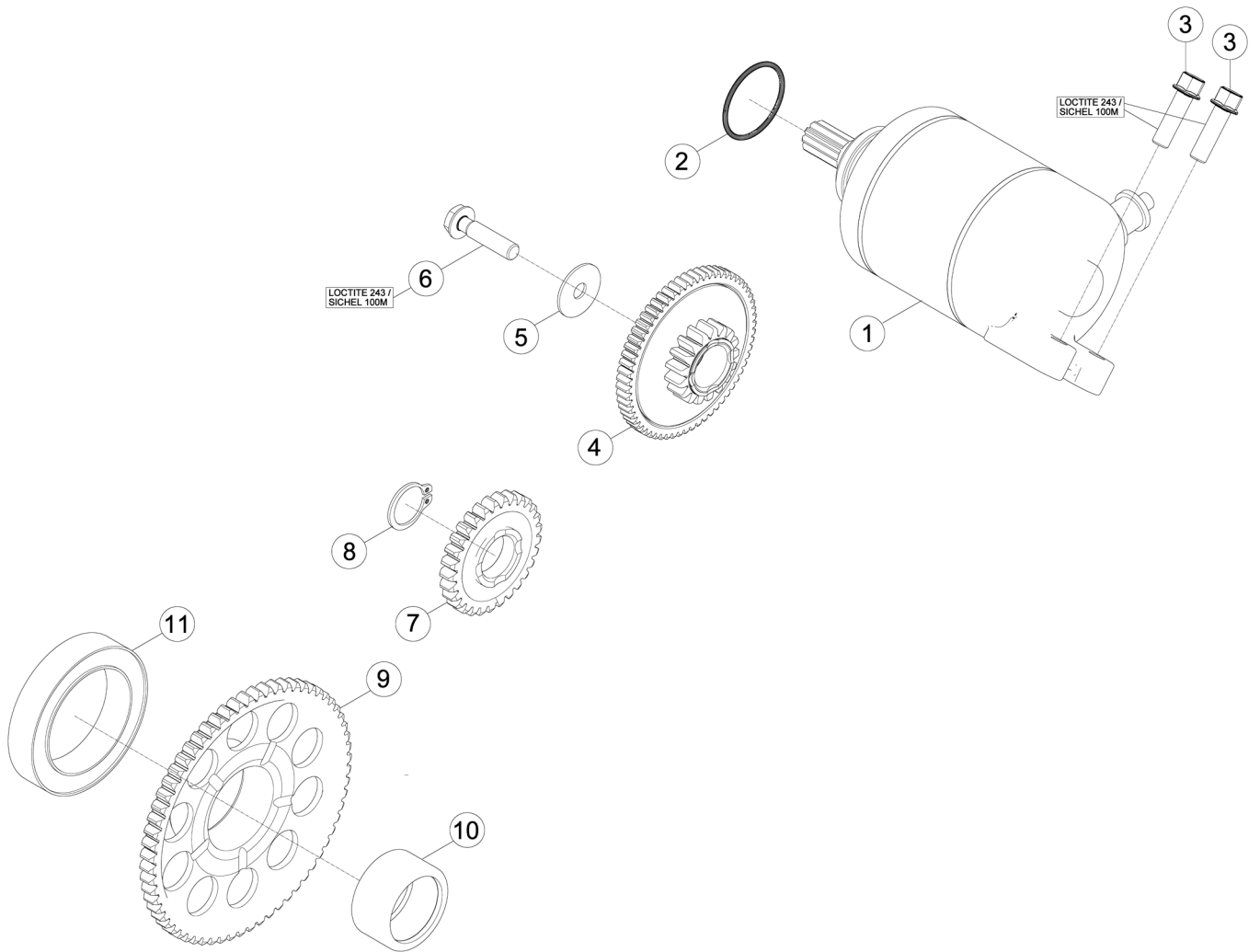

Pos Loc Pos Ps Pos	Numero Number Numéro Número Nummer	Q.tà Q.ty Q.té M.ge C.ad	Nota Note Note Nota Anm.	Descrizione	Description	Désignation	Beschreibung	Descrìpziòn
1	006070000 000	1		Motorino avviamento 0,45KW	Starter motor 0,45KW	Moteur du démarreur 0,45KW	Startermotor 0,45KW	Motor de arranque 0,45KW
2	3625056 000	1		Anello OR 25,00x3,00	O-Ring 25,00x3,00	Bague d'étanchéité 25,00x3,00	O-Ring 25,00x3,00	Anillo OR 25,00x3,00
3	1149070 000	2		Bullone 6x20 ch rs	Bolt 6x20 ch rs	Boulon 6x20 ch rs	Bolzen 6x20 ch rs	Tornillo 6x20 ch rs
4	006071108 000	1		Limitatore di coppia	Torque limiting	Limiteur de couple	Drehmomentbegrenzer - Geführte Puffer	Limitador de par de torsion
5	2742015 150	1		Rondella spessoramento 6x20.1,50	Spacer washer 6x20.1,50	Entretoise 6x20.1,50	Distanzscheibe 6x20.1,50	Arandela distanciadora 6x20.1,50
6	1150010 000	1		Bullone M6x25	Bolt M6x25	Boulon M6x25	Bolzen M6x25	Tornillo M6x25
7	006071200 000	1		Ingranaggio ozioso	Idle gear	Engrenage parasite	Zahnrad	Engranaje parásita
8	2824460 000	1		Seeger 16x1	Circlip 16x1	Circlip 16x1	Seeger 16x1	Seeger 16x1
9	006070300 000	1		Ingranaggio avviamento	Starter gear	Engrenage du démarreur	Starterzahnrad	Engranaje puesta en marcha
10	006070310 000	1		Boccola a rulli HK 2516	Roller bearing HK 2516	Douille à roulements HK 2516	Rollenbuchse HK 2516	Caja de grasa de rodillos HK 2516
11	006070400 000	1		Ruota libera	Free wheel	Roue libre	Freilauf	Rueda libre

# Tav.10

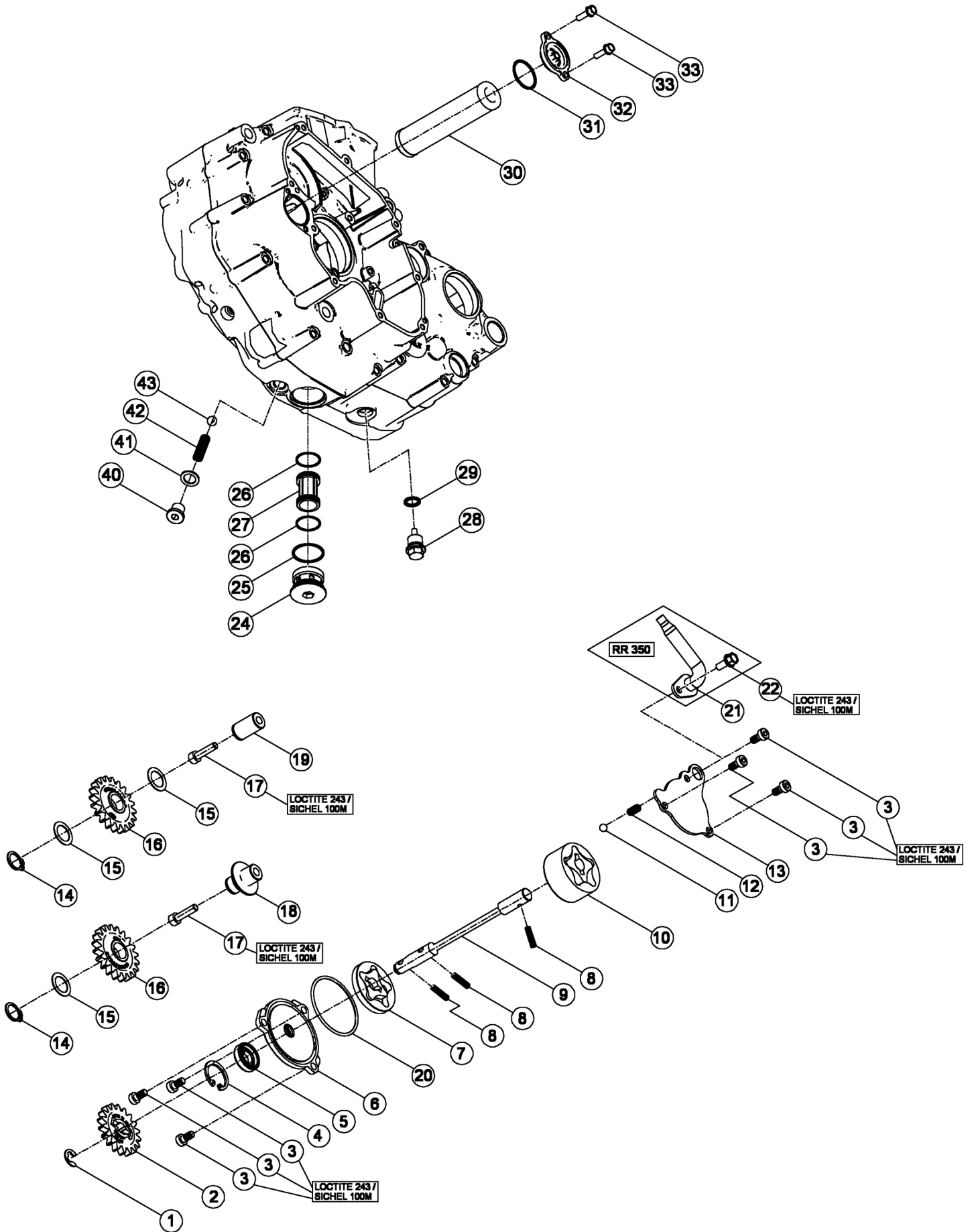

**Beta**  
the play bike

# Tav.10

Pos Loc Pos Ps Pos	Numero Number Numéro Número Nummer	Q.tà Q.ty Q.té M.ge C.ad	Nota Note Note Nota Anm.	Descrizione	Description	Désignation	Beschreibung	Descripcìon
1	2822645 000	1		Seeger RA 7	Circlip RA 7	Circlip RA 7	Seeger RA 7	Seeger RA 7
2	006080220 000	1		Ingranaggio pompa olio	Oil pump gear	Engrenage pompe huile	Zahnrad Ölpumpe	Engranaje bomba aceite
3	3129823 000	6		Vite MSX10	Screw MSX10	Vis MSX10	Schraube MSX10	Tornillo MSX10
4	2825502 000	1		Seeger JS24	Circlip JS24	Circlip JS24	Seeger JS24	Seeger JS24
5	1044695 000	1		Anello paraolio 10x22.6	Oil seal 10x22.6	Joint d'étanchéité 10x22.6	Ölschutzring 10x22.6	Retén de aceite 10x22.6
6	006080110 000	1		Coperchio pompa olio	Oil pump cover	Couvercle pompe huile	Ölpumpendeckel	Tapa bomba aceite
7	006080108 000	1		Pompa olio D=40,56 B=5	Oil pump D=40,56 B=5	Pompe huile D=40,56 B=5	Ölpumpe D=40,56 B=5	Bomba aceite D=40,56 B=5
8	1293384 000	3		Rullino 4x15,8	Roller 4x15,8	Rouleau 4x15,8	Rolle 4x15,8	Rodillo 4x15,8
9	006081200 000	1		Albero pompa olio	Oil pump shaft	Arbre de pompe à huile	Ölpumpenwelle	Eje bomba aceite
10	006080008 000	1		Pompa olio D=40,56 B=19	Oil pump D=40,56 B=19	Pompe huile D=40,56 B=19	Ölpumpe D=40,56 B=19	Bomba aceite D=40,56 B=19
11	2890220 000	1		Sfera Dx5,5	Ball Dx5,5	Bille Dx5,5	Kugel Dx5,5	Bola Dx5,5
12	006080410 000	1		Molla	Spring	Ressort	Feder	Muelle
13	022080010 000	1		Coperchio pompa olio	Oil pump cover	Couvercle pompe huile	Ölpumpendeckel	Tapa bomba aceite
14	2822810 000	2		Seeger A13	Circlip A13	Circlip A13	Seeger A13	Seeger A13
15	2761395 050	3		Rondella spessoramento 13x19,0,50	Spacer washer 13x19,0,50	Entretoise 13x19,0,50	Distanzscheibe 13x19,0,50	Arandela distanciadora 13x19,0,50
16	006080300 000	2		Rinvio ingranaggio pompa olio	Oil pump gear	Renvoi engrenage pompe huile	Zahnrad Ölpumpe	Reenvío engranaje bomba aceite
17	3130015 000	2		Vite a brugola 5x20	Allen screw 5x20	Vis à 6 pans 5x20	Sechskantschraube 5x20	Tornillo a llave allen 5x20
18	006081310 000	1		Perno	Pin	Pivot	Zapfen	Perno
19	006080320 000	1		Perno	Pin	Pivot	Zapfen	Perno
20	1066934 000	1		Anello OR 45 x 2	O-Ring 45 x 2	Bague d'étanchéité 45 x 2	O-Ring 45 x 2	Anillo OR 45 x 2
21	022080028 000	1		Piastra lubrificazione	Lubrication plate	Plaque lubrification	Schmierungsplatte	Chapa lubricación
22	1146251 000	2		Bullone flangiato M5x12	Head Flanged bolt M5x12	Boulon Bridé M5x12	Bundbolzen M5x12	Bulón con Brida M5x12
24	006081508 000	1		Tappo scarico olio	Oil exh. plug	Bouchon dech. huile	Oelablassschraube	Tapón de descarga aceite
25	1066675 000	1		Anello OR 27 x 2	O-Ring 27 x 2	Bague d'étanchéité 27 x 2	O-Ring 27 x 2	Anillo OR 27 x 2
26	1066465 000	2		Anello OR 20 x 1,5.	O-Ring 20 x 1,5.	Bague d'étanchéité 20 x 1,5.	O-Ring 20 x 1,5.	Anillo OR 20 x 1,5.
27	006080518 000	1		Filtro olio	Oil filter	Filtre à huile	Ölfilter	Filtro de aceite
28	006081528 000	1		Tappo per scarico olio	Oil drainplug	Bouchon de vidange d'huile	Ölablassstopfen	Tapón para el escape de aceite
29	1066164 000	1		Anello Or 11x2,5 nbr70 sh	O-Ring 11x2,5 nbr70 sh	Bague d'étanchéité 11x2,5	O-Ring 11x2,5 nbr70 sh nbr70 sh	Anillo OR 11x2,5 nbr70 sh
30	006080700 000	1		Filtro olio	Oil filter	Filtre à huile	Ölfilter	Filtro de aceite
31	1066685 000	1		Anello OR 28 x 1,5	O-Ring 28 x 1,5	Bague d'étanchéité 28 x 1,5	O-Ring 28 x 1,5	Anillo OR 28 x 1,5
31	1066675 000	1	FACTORY	Anello OR 27,2	O-Ring 27,2	Bague d'étanchéité 27,2	O-Ring 27,2	Anillo OR 27,2
32	006080600 000	1		Tappo filtro olio	Oil filter plug	Bouchon filtre huile	Ölfilterverschluss	Tapa filtro aceite
32	006080600 053	1	FACTORY	Tappo filtro olio	Oil filter plug	Bouchon filtre huile	Ölfilterverschluss	Tapa filtro aceite
33	1146360 000	2		Bullone flangiato M5x16	Head Flanged bolt M5x16	Boulon Bridé M5x16	Bundbolzen M5x16	Bulón con Brida M5x16
40	3625062 000	2		Tappo M12 X 1,5	Plug M12 X 1,5	Bouchon M12 X 1,5	Verschluß M12 X 1,5	Tapón M12 X 1,5
41	2760265 000	1		Rondella rasamento 12x18x1,5	Thrust washer 12x18x1,5	Rondelle de butée 12x18x1,5	Anlaufscheibe 12x18x1,5	Arandela distanciadora 12x18x1,5
42	006080400 000	1		Molla	Spring	Ressort	Feder	Muelle
43	2890225 000	1		Sfera Dx9	Ball Dx9	Bille Dx9	Kugel Dx9	Bola Dx9

# Tav.11

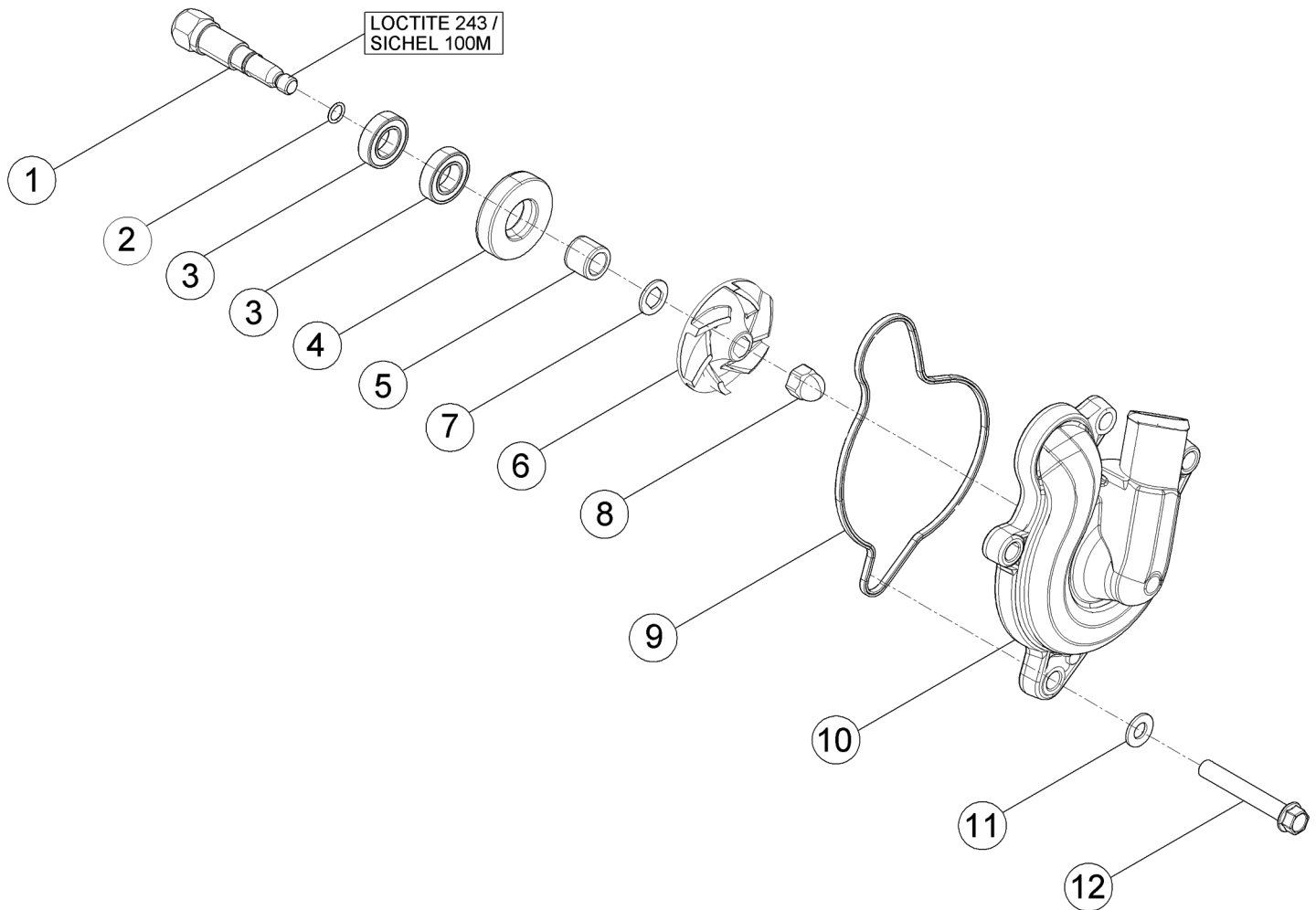

Pos Loc Pos Ps Pos	Numero Number Numéro Número Nummer	Q.tà Q.ty Q.té M.ge C.ad	Nota Note Note Nota Anm.	Descrizione	Description	Désignation	Beschreibung	Descripció
1	006090100 000	1		Albero pompa acqua	Coolant pump shaft	Arbre de pompe a eau	Wasserpumpenwelle	Eje bomba de agua
2	1066136 000	1		Anello OR 5,5x1	O-Ring 5,5x1	Bague d'étanchéité 5,5x1	O-Ring 5,5x1	Anillo OR 5,5x1
3	1293400 000	2		Cuscinetto 10x19.5	Bearing 10x19.5	Roulement 10x19.5	Lager 10x19.5	Cojinete 10x19.5
4	1048030 000	1		Anello paraolio 12x30.7	Oil seal 12x30.7	Joint d'étanchéité 12x30.7	Ölschutzring 12x30.7	Retén de aceite 12x30.7
5	006090110 000	1		Boccola 8x12.10	Bush 8x12.10	Moyeu 8x12.10	Büchse 8x12.10	Buje 8x12.10
6	006090000 000	1		Girante pompa	Rotor	Roue de pompe	Wasserpumpenrad	Rotor de la bomba
7	006090120 000	1		Rondella	Washer	Rondelle	U.Scheibe	Arandela
8	1311520 000	1		Dado M6X1	Nut M6X1	Ecrou M6X1	Mutter M6X1	Tuerca M6X1
9	006090210 000	1		Guarnizione pompa acqua	Water pump gasket	Joint pompe eau	Dichtung Wasserpumpe	Empaque bomba agua
10	006090200 000	1		Coperchio pompa acqua	Water pump cover	Couvercle pompe à eau	Wasserpumpendeckel	Tapa bomba agua
11	2758000 000	1		Rondella	Washer	Rondelle	U.Scheibe	Arandela
12	1150360 000	4		Bullone M6x40	Bolt M6x40	Boulon M6x40	Bolzen M6x40	Tornillo M6x40



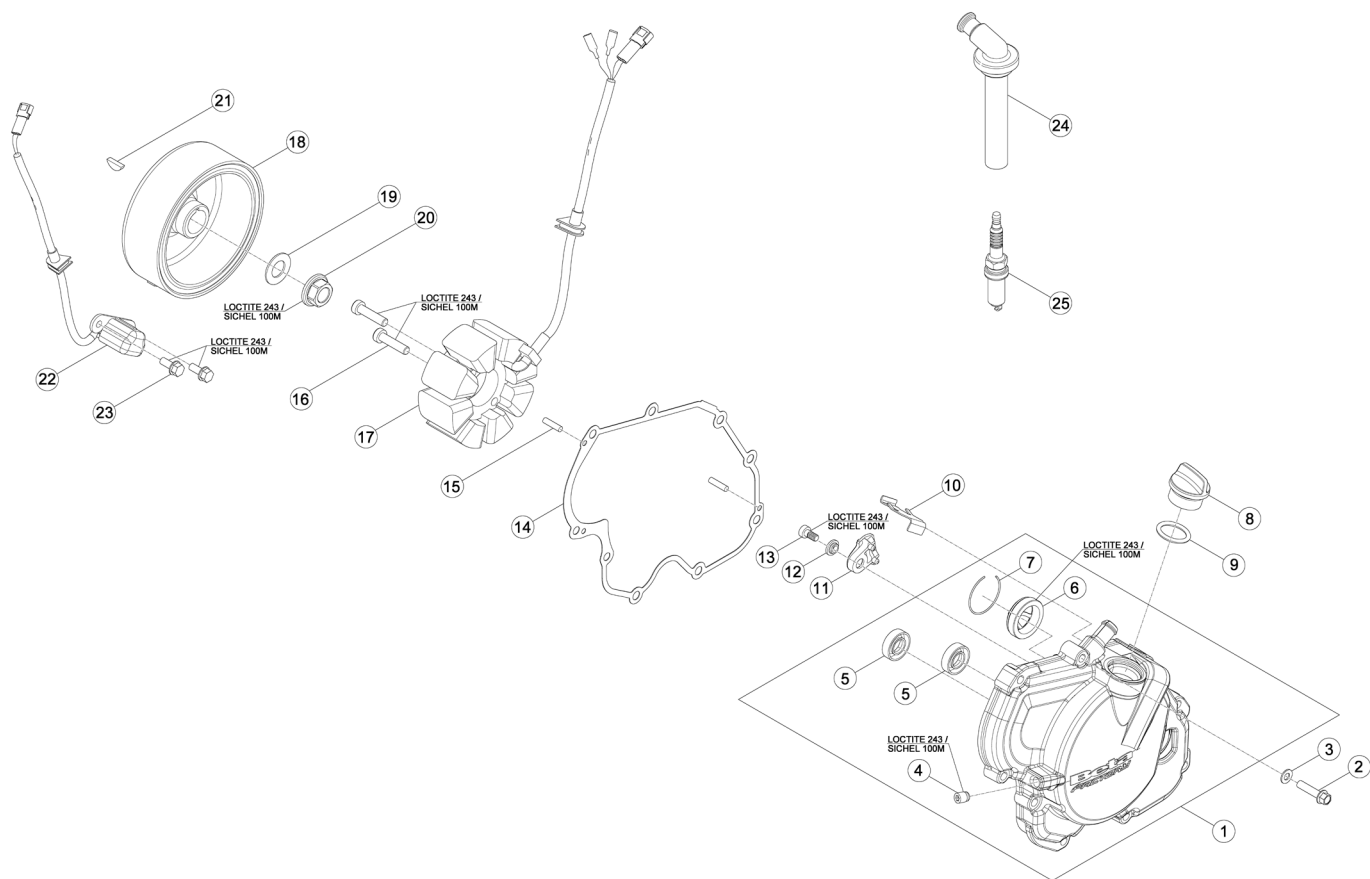

Pos	Numero	Q.tà	Nota	Descrizione	Description	Désignation	Beschreibung	Descripció
Loc	Number	Q.ty	Note					
Pos	Número	Q.té	Note					
Ps	Número	M.ge	Nota					
Pos	Nummer	C.ad	Anm.					
1	006010508 052	1		Coperchio volano	Flywheel cover	Carter volant	Schwungraddeckel	Tapa volante
2	1150010 000	9		Bullone M6x25	Bolt M6x25	Boulon M6x25	Bolzen M6x25	Tornillo M6x25
3	2758000 000	1		Rondella	Washer	Rondelle	U.Scheibe	Arandela
4	006010210 000	1		Tappo olio ad espansione 7X9	Oil expansion plug 7X9	Bouchon d'huile à expansion 7X9	Öl-expansionsstopfen 7X9	Tapón extensible del aceite 7X9
5	1044690 000	2		Anello paraolio 10x22.6	Oil seal 10x22.6	Joint d'étanchéité 10x22.6	Ölschutzring 10x22.6	Retén de aceite 10x22.6
6	006010560 000	1		Oblò ispezione livello olio	Oil level sight glass	Hublot d'inspection niveau huile	Ölkontrollschauglas	Visor de inspección nivel aceite
7	2825680 000	1		Seeger 30X1	Circlip 30X1	Circlip 30X1	Seeger 30X1	Seeger 30X1
8	2909601 000	1		Tappo carico olio	Oil filling cap	Bouchon rempl. huile	Öleinfüllstöpsel	Tapón intruducción aceite
8	2909601 053	1	FACTORY	Tappo carico olio	Oil filling cap	Bouchon rempl. huile	Öleinfüllstöpsel	Tapón intruducción aceite
9	1066340 000	1		Anello OR 16x3	O-Ring 16x3	Bague d'étanchéité 16x3	O-Ring 16x3	Anillo OR 16x3
10	006010540 000	1		Piastrina	Plate	Plaquette	Plättchen	Placa
11	006110700 000	1		Guida catena	Chain guide	Guide chaîne	Kettenführung	Guía cadena
12	006080810 000	1		Boccola	Bush	Moyeu	Büchse	Buje
13	3129823 000	1		Vite M5X10	Screw M5X10	Vis M5X10	Schraube M5X10	Tornillo M5X10
14	006010510 000	1		Guarnizione coperchio volano	Alternator cover gasket	Garniture couvercle alternateur	Alternatordeckeldichtung	Junta tapa alternador
15	1293384 000	2		Rullino 4x15,8	Roller 4x15,8	Rouleau 4x15,8	Rolle 4x15,8	Rodillo 4x15,8
16	3148507 000	2		Vite tce testa ribassata M6x25	Screw tce, shallow head M6x25	Vis tce à tête basse M6x25	Schraube tce senkkopf M6x25	Tornillo tce de cabeza rebajada M6x25
17	006100200 000	1		Statore	Backplate	Stator	Ankerplatte	Estatore
18	006100100 000	1		Rotore	Rotor	Rotor	Rotor	Rotor
19	2774810 000	1		Rondella elastica	Spring Washer	Rondelle élastique	Federring	Arandela elástica
20	1325010 000	1		Dado M12x1	Nut M12x1	Ecrou M12x1	Mutter M12x1	Tuerca M12x1
21	1246020 000	1		Chiavetta 3x5	Key 3x5	Clavette 3x5	Keil 3x5	Chaveta 3x5
22	006100300 000	1		Bullone flangiato M5x12	Head Flanged bolt M5x12	Boulon Bridé M5x12	Bundbolzen M5x12	Bulón con Brida M5x12
23	1146251 000	2		Bullone flangiato M5x12	Head Flanged bolt M5x12	Boulon Bridé M5x12	Bundbolzen M5x12	Bulón con Brida M5x12
24	006100550 000	1		Cappuccio candela	Spark plug cap	Capuchon/couvercle bougie	Zündkerzenkappe	Capuchón de la bujía
25	006100500 000	1		Candela M12X1,25	Spark plug M12X1,25	Bougie M12X1,25	Zündkerze M12X1,25	Bujía M12X1,25

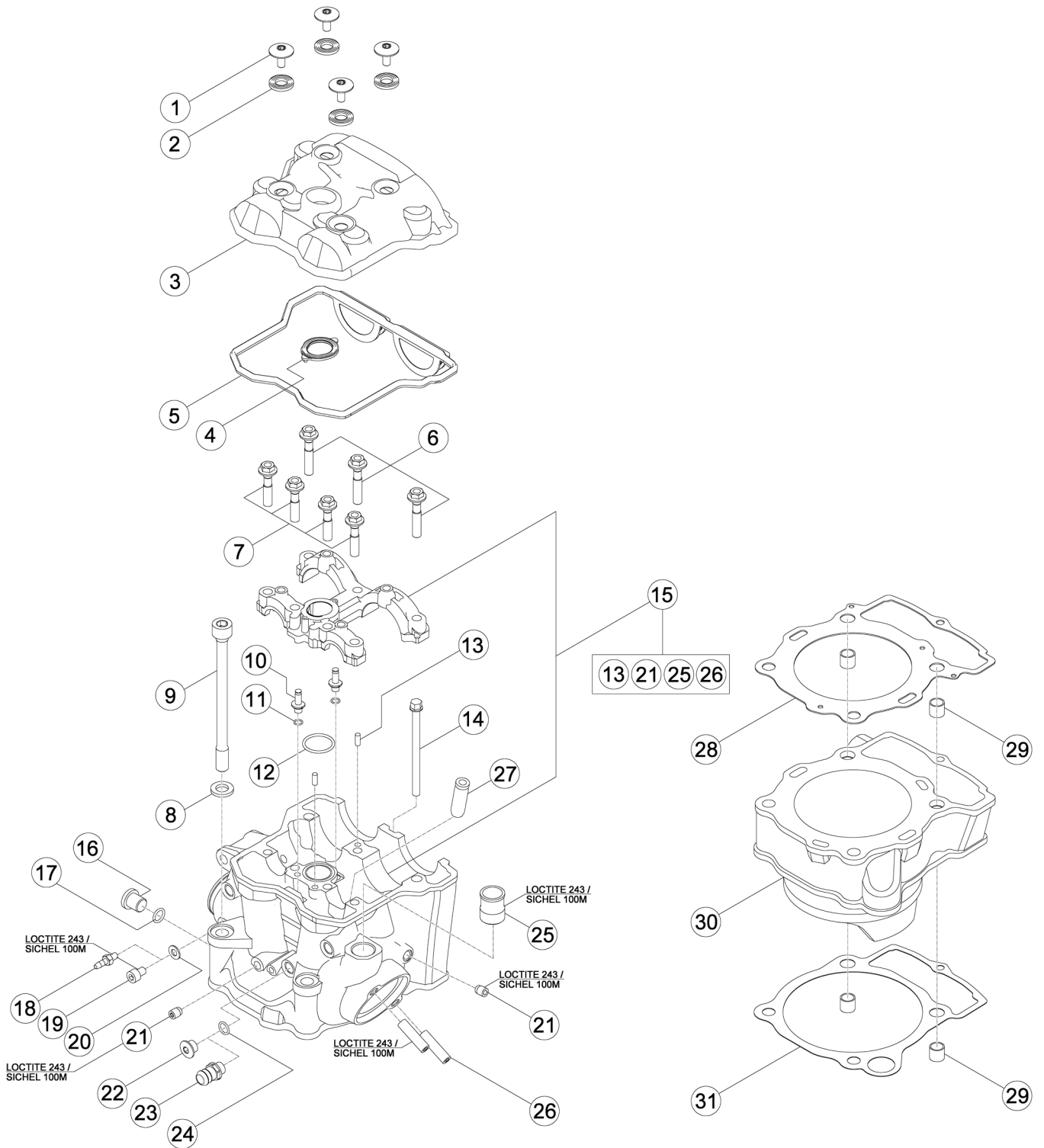



# Tav.13

Pos Loc Pos Ps Pos	Numero Number Numéro Número Nummer	Q.tà Q.ty Q.té M.ge C.ad	Nota Note Note Nota Anm.	Descrizione	Description	Désignation	Beschreibung	Descripcìon
1	006110250 000	4		Vite coperchio testa	Cylinder head cover screw	Vis couvercle culasse	Schraube Zylinderkopfabdeckung	Tornillo tapa culata
2	006110260 000	4		Guarnizione	Packing	Joint	Dichtung	Junta
3	006110200 052	1		Coperchio testa	Cylinder head cover	Couvercle culasse	Zylinderkopfabdeckung	Tapa culata
4	006110220 000	1		Guarnizione sede candela	Packing spark-plug connector	Joint fiche bougie	Dichtung Kerzenstecker	Junta enchufe para bujia
5	006110210 000	1		Guarnizione coperchio testa	Cylinder head cover gasket	Joint couvercle culasse	Dichtung Zylinderkopfabdeckung	Junta tapa culata
6	1152427 000	3		Bullone speciale 7x38	Special bolt 7x38	Boulon spéciale 7x38	Spezialschraube 7x38	Tornillo especial 7x38
7	1152425 000	4		Bullone speciale 7x33	Special bolt 7x33	Boulon spéciale 7x33	Spezialschraube 7x33	Tornillo especial 7x33
8	006110120 000	4		Distanziale 10,5X18,5X2,5	Spacer 10,5X18,5X2,5	Entretoise 10,5X18,5X2,5	Distanzstück 10,5X18,5X2,5	Distanciadór 10,5X18,5X2,5
9	022110130 000	4	350	Vite M10x1,25 L=127,5	Screw M10x1,25 L=127,5	Vis M10x1,25 L=127,5	Schraube M10x1,25 L=127,5	Tornillo M10x1,25 L=127,5
9	006110130 000	4	400-450 520	Vite M10x1,25	Screw M10x1,25	Vis M10x1,25	Schraube M10x1,25	Tornillo M10x1,25
10	006110090 000	2		Getto	Jet	Gicleur	Düse	Surtidor
11	1066136 000	2		Anello OR 5,5x1	O-Ring 5,5x1	Bague d'étanchéité 5,5x1	O-Ring 5,5x1	Anillo OR 5,5x1
12	1066495 000	1		Anello OR 22x2	O-Ring 22x2	Bague d'étanchéité 22x2	O-Ring 22x2	Anillo OR 22x2
13	3625021 000	2		Rullino 4,0 X 9,8	Roller 4,0 X 9,8	Rouleau 4,0 X 9,8	Rolle 4,0 X 9,8	Rodillo 4,0 X 9,8
14	3625013 000	1	350	Bullone 6x75	Bolt 6x75	Boulon 6x75	Bolzen 6x75	Tornillo 6x75
14	1105445 000	1	400-450 520	Bullone 6x80	Bolt 6x80	Boulon 6x80	Bolzen 6x80	Tornillo 6x80
15	022110008 000	1	350	Testa completa	Cylinder head	Culasse complete	Zylinderkopf Kpl.	Culata completa
15	006110008 000	1	400-450 520	Testa completa	Cylinder head	Culasse complete	Zylinderkopf Kpl.	Culata completa
16	3625062 000	1		Tappo M12 X 1,5	Plug M12 X 1,5	Bouchon M12 X 1,5	Verschluss M12 X 1,5	Tapón M12 X 1,5
17	1066195 000	1		Anello OR 9,25x1,78	O-Ring 9,25x1,78	Bague d'étanchéité 9,25x1,78	O-Ring 9,25x1,78	Anillo OR 9,25x1,78
18	2900280 000	1		Tappo presa dep.	Air Vent Plug	Bouchon prise dep.	Verschluss f. Lufteinlass	Tapón Toma Aire dep.
19	1146491 000	1		Bullone 6x8	Bolt 6x8	Boulon 6x8	Bolzen 6x8	Tornillo 6x8
20	2758000 000	1		Rondella	Washer	Rondelle	U.Scheibe	Arandela
21	006010210 000	2		Tappo olio ad espansione 7X9	Oil expansion plug 7X9	Bouchon d'huile à expansion 7X9	Öl-expansionsstopfen 7X9	Tapón extensible del aceite 7X9
22	006110450 000	1		Tappo Albero coperchio frizione	Clutch cover Arm Plug	Bouchon Arbre	Endkappe Kupplungsdeckel	Tapa Ciguenal embrague
22	006150060 000	1	FACTORY	Tappo Albero coperchio frizione	Clutch cover Arm Plug	Bouchon Arbre Couvercle d'embrayage	Endkappe Kupplungsdeckel	Tapa Ciguenal embrague
23	006010270 000	1		Raccordo	Joint.p.	Raccord	Stutzen	Racor
24	1050010 000	1		Anello OR 8x1,5x	O-Ring 8x1,5x	Bague d'étanchéité 8x1,5x	O-Ring 8x1,5x	Anillo OR 8x1,5x
25	006111080 000	1		Raccordo uscita acqua M20x1,25	Water outlet union M20x1,25	Raccord évacuation d'eau M20x1,25	Anschluß für Wasserblauf M20x1,25	Conexión salida agua M20x1,25
26	006110190 000	2		Prigioniero M8X30	Stud M8X30	Goujon M8X30	Stiftschraube M8X30	Espárrago M8X30
27	006110050 000	4		Guida valvola	Valve guide	Guide soupape	Ventilführung	Guía válvula
28	022020630 000	1	350	Guarnizione testa D=88	Cylinder head gasket D=88	Joint Culasse D=88	Zylinderkopfdichtung D=88	Junta de culata D=88
28	006020630 000	1	400-450	Guarnizione testa D=95	Cylinder head gasket D=95	Joint Culasse D=95	Zylinderkopfdichtung D=95	Junta de culata D=95
28	006021630 000	1	520	Guarnizione testa D=100	Cylinder head gasket D=100	Joint Culasse D=100	Zylinderkopfdichtung D=100	Junta de culata D=100
29	006020700 000	4		Boccola 10,5x12x11	Bush 10,5x12x11	Moyeu 10,5x12x11	Büchse 10,5x12x11	Buje 10,5x12x11
30	022020600 001	1	350	Cilindro D=88 misura 1	Cylinder D=88 size 1	Cylindre D=88 taille 1	Zylinder D=88 ausmessen 1	Cilindro D=88 misura 1
30	006020600 001	1	400-450	Cilindro D=95 misura 1	Cylinder D=95 size 1	Cylindre D=95 taille 1	Zylinder D=95 ausmessen 1	Cilindro D=95 misura 1
30	006021600 001	1	520	Cilindro D=100 misura 1	Cylinder D=100 size 1	Cylindre D=100 taille 1	Zylinder D=100 ausmessen 1	Cilindro D=100 misura 1
30	022020600 002	1	350	Cilindro D=88 misura 2	Cylinder D=88 size 2	Cylindre D=88 taille 2	Zylinder D=88 ausmessen 2	Cilindro D=88 misura 2
30	006020600 002	1	400-450	Cilindro D=95 misura 2	Cylinder D=95 size 2	Cylindre D=95 taille 2	Zylinder D=95 ausmessen 2	Cilindro D=95 misura 2
30	006021600 002	1	520	Cilindro D=100 misura 2	Cylinder D=100 size 2	Cylindre D=100 taille 2	Zylinder D=100 ausmessen 2	Cilindro D=100 misura 2
31	022020620 000	1	350	Guarnizione base cilindro 0,5MM	Cylinder base gasket 0,5MM	Garniture base cylindre 0,5MM	Dichtung für Zylinderfuß 0,5MM	Junta base cilindro 0,5MM
31	006020620 000	1	400-450 520	Guarnizione base cilindro 0,5MM	Cylinder base gasket 0,5MM	Garniture base cylindre 0,5MM	Dichtung für Zylinderfuß 0,5MM	Junta base cilindro 0,5MM
31	006150100 000	1	400-450 FACTORY	Guarnizione base cilindro 0,3MM	Cylinder base gasket 0,3MM	Garniture base cylindre 0,3MM	Dichtung für Zylinderfuß 0,3MM	Junta base cilindro 0,3MM

# Tav.14

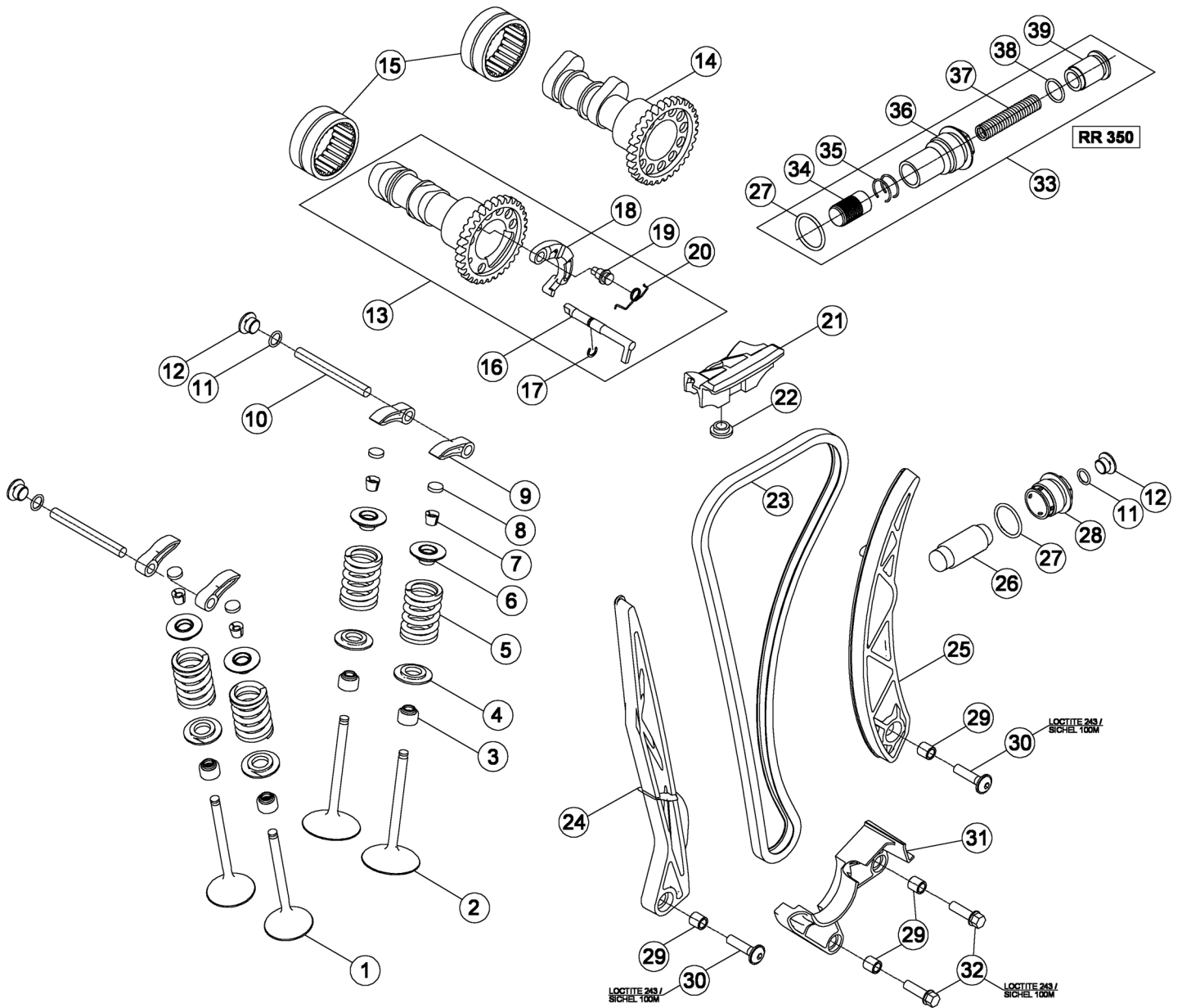

**Beta**  
the play bike

# Tav.14

Pos Loc Pos Ps Pos	Numero Number Numéro Número Nummer	Q.tà Q.ty Q.té M.ge C.ad	Nota Note Note Nota Anm.	Descrizione	Description	Désignation	Beschreibung	Descripción
1	022110330 000	2	350	Valvola scarico	Exhaust valve	Soupape d'éch.	Auslaßventil	Válvula de escape
1	006111330 000	2	400-450 520	Valvola scarico	Exhaust valve	Soupape d'éch.	Auslaßventil	Válvula de escape
2	022110320 000	2	350	Valvola aspirazione	Suction valve	Soupape aspir.	Einlaßventil	Válvula aspiración
2	006110320 000	2	400-450 520	Valvola aspirazione	Suction valve	Soupape aspir.	Einlaßventil	Válvula aspiración
3	006111390 000	4		Gambo Valvole	Gambo Valves	Tige Valves	Ventilschaftdichtung	Brazo Valvulas
4	006110370 000	4		Scodellino inferiore	Lower stop washer	Rondelle d'arrêt inférieure	Unterer Federaufnahme	Platillo inferior
5	006110340 000	4		Molla valvola	Valve spring	Ressort soupape	Ventilfeder	Muelle válvula
6	022110360 000	4		Scodellino superiore	Upper stop washer	Rondelle d'arrêt supérieure	Oberer Federaufnahme	Platillo superior
7	006110380 000	8		Semicono	Cone, half	Demi bague	Buchse halb	Semicasquillo
8	006110402 000	1	2,000	Rondella spessore	Shim	Rondelle entretoise	Ausgleichscheibe	Arandela suplemento
8	006110402 005	1	2,050	Rondella spessore	Shim	Rondelle entretoise	Ausgleichscheibe	Arandela suplemento
8	006110402 010	1	2,100	Rondella spessore	Shim	Rondelle entretoise	Ausgleichscheibe	Arandela suplemento
8	006110402 015	1	2,150	Rondella spessore	Shim	Rondelle entretoise	Ausgleichscheibe	Arandela suplemento
8	006110402 020	1	2,200	Rondella spessore	Shim	Rondelle entretoise	Ausgleichscheibe	Arandela suplemento
8	006110402 025	1	2,250	Rondella spessore	Shim	Rondelle entretoise	Ausgleichscheibe	Arandela suplemento
8	006110402 030	1	2,300	Rondella spessore	Shim	Rondelle entretoise	Ausgleichscheibe	Arandela suplemento
8	006110402 032	1	2,325	Rondella spessore	Shim	Rondelle entretoise	Ausgleichscheibe	Arandela suplemento
8	006110402 035	1	2,350	Rondella spessore	Shim	Rondelle entretoise	Ausgleichscheibe	Arandela suplemento
8	006110402 037	1	2,375	Rondella spessore	Shim	Rondelle entretoise	Ausgleichscheibe	Arandela suplemento
8	006110402 040	1	2,400	Rondella spessore	Shim	Rondelle entretoise	Ausgleichscheibe	Arandela suplemento
8	006110402 042	1	2,425	Rondella spessore	Shim	Rondelle entretoise	Ausgleichscheibe	Arandela suplemento
8	006110402 045	1	2,450	Rondella spessore	Shim	Rondelle entretoise	Ausgleichscheibe	Arandela suplemento
8	006110402 047	1	2,475	Rondella spessore	Shim	Rondelle entretoise	Ausgleichscheibe	Arandela suplemento
8	006110402 050	1	2,500	Rondella spessore	Shim	Rondelle entretoise	Ausgleichscheibe	Arandela suplemento
8	006110402 052	1	2,525	Rondella spessore	Shim	Rondelle entretoise	Ausgleichscheibe	Arandela suplemento
8	006110402 055	1	2,550	Rondella spessore	Shim	Rondelle entretoise	Ausgleichscheibe	Arandela suplemento
8	006110402 057	1	2,575	Rondella spessore	Shim	Rondelle entretoise	Ausgleichscheibe	Arandela suplemento
8	006110402 060	1	2,600	Rondella spessore	Shim	Rondelle entretoise	Ausgleichscheibe	Arandela suplemento
8	006110402 062	1	2,625	Rondella spessore	Shim	Rondelle entretoise	Ausgleichscheibe	Arandela suplemento
8	006110402 065	1	2,650	Rondella spessore	Shim	Rondelle entretoise	Ausgleichscheibe	Arandela suplemento
8	006110402 067	1	2,675	Rondella spessore	Shim	Rondelle entretoise	Ausgleichscheibe	Arandela suplemento
8	006110402 070	1	2,700	Rondella spessore	Shim	Rondelle entretoise	Ausgleichscheibe	Arandela suplemento
8	006110402 072	1	2,725	Rondella spessore	Shim	Rondelle entretoise	Ausgleichscheibe	Arandela suplemento
8	006110402 075	1	2,750	Rondella spessore	Shim	Rondelle entretoise	Ausgleichscheibe	Arandela suplemento
8	006110402 077	1	2,775	Rondella spessore	Shim	Rondelle entretoise	Ausgleichscheibe	Arandela suplemento
8	006110402 080	1	2,800	Rondella spessore	Shim	Rondelle entretoise	Ausgleichscheibe	Arandela suplemento
8	006110402 082	1	2,825	Rondella spessore	Shim	Rondelle entretoise	Ausgleichscheibe	Arandela suplemento
8	006110402 085	1	2,850	Rondella spessore	Shim	Rondelle entretoise	Ausgleichscheibe	Arandela suplemento
8	006110402 087	1	2,875	Rondella spessore	Shim	Rondelle entretoise	Ausgleichscheibe	Arandela suplemento
8	006110402 090	1	2,900	Rondella spessore	Shim	Rondelle entretoise	Ausgleichscheibe	Arandela suplemento
8	006110402 092	1	2,925	Rondella spessore	Shim	Rondelle entretoise	Ausgleichscheibe	Arandela suplemento
8	006110402 095	1	2,950	Rondella spessore	Shim	Rondelle entretoise	Ausgleichscheibe	Arandela suplemento
8	006110402 097	1	2,975	Rondella spessore	Shim	Rondelle entretoise	Ausgleichscheibe	Arandela suplemento
8	006110403 000	1	3,000	Rondella spessore	Shim	Rondelle entretoise	Ausgleichscheibe	Arandela suplemento
8	006110403 005	1	3,050	Rondella spessore	Shim	Rondelle entretoise	Ausgleichscheibe	Arandela suplemento
8	006110403 010	1	3,100	Rondella spessore	Shim	Rondelle entretoise	Ausgleichscheibe	Arandela suplemento
8	006110403 015	1	3,150	Rondella spessore	Shim	Rondelle entretoise	Ausgleichscheibe	Arandela suplemento
8	006110403 020	1	3,200	Rondella spessore	Shim	Rondelle entretoise	Ausgleichscheibe	Arandela suplemento
9	006110300 000	4		Bilanciere	Lever	Balancier	Kipphebel	Balancin
10	006110310 000	2		Perno bilanciante	Rocker shaft	Axe culbuteur	Kipphebel-Federwelle	Eje balancin
11	1050010 000	3		Anello OR 8x1,5x	O-Ring 8x1,5x	Bague d'étanchéité 8x1,5x	O-Ring 8x1,5x	Anillo OR 8x1,5x
12	006110450 000	3		Tappo Albero coperchio frizione	Clutch cover Arm Plug	Bouchon Arbre	Endkappe Kupplungsdeckel	Tapa Ciguena embrague
12	006150060 000	3	FACTORY	Tappo Albero coperchio frizione	Clutch cover Arm Plug	Couvercle d'embrayage Bouchon Arbre Couvercle d'embrayage	Endkappe Kupplungsdeckel	Tapa Ciguena embrague
13	022110518 000	1	350	Albero a camme SCARICO	Camshaft EXHAUST	Arbre distr. ECHAPPEMENT	Nockenwelle AUSPUFFSEITE	Eje distribución DESCARGA
13	006112518 000	1	400	Albero a camme SCARICO	Camshaft EXHAUST	Arbre distr. ECHAPPEMENT	Nockenwelle AUSPUFFSEITE	Eje distribución DESCARGA
13	006110518 000	1	450-520	Albero a camme SCARICO	Camshaft EXHAUST	Arbre distr. ECHAPPEMENT	Nockenwelle AUSPUFFSEITE	Eje distribución DESCARGA
14	022110500 000	1	350	Albero a camme ASPIRAZIONE	Camshaft INTAKE	Arbre distribution ADMISSION	Nockenwelle ANSAUGSEITE	Eje distribución ASPIRACIÓN
14	006112500 000	1	400	Albero a camme ASPIRAZIONE	Camshaft INTAKE	Arbre distribution ADMISSION	Nockenwelle ANSAUGSEITE	Eje distribución ASPIRACIÓN
14	006110500 000	1	450	Albero a camme ASPIRAZIONE	Camshaft INTAKE	Arbre distribution ADMISSION	Nockenwelle ANSAUGSEITE	Eje distribución ASPIRACIÓN
14	006111500 000	1	520	Albero a camme ASPIRAZIONE	Camshaft INTAKE	Arbre distribution ADMISSION	Nockenwelle ANSAUGSEITE	Eje distribución ASPIRACIÓN
15	006110530 000	2		Cuscinetto a rulli	Roller bearing	Roulément à aiguilles	Rollenlager	Cojinete de rodillos

# Tav.14

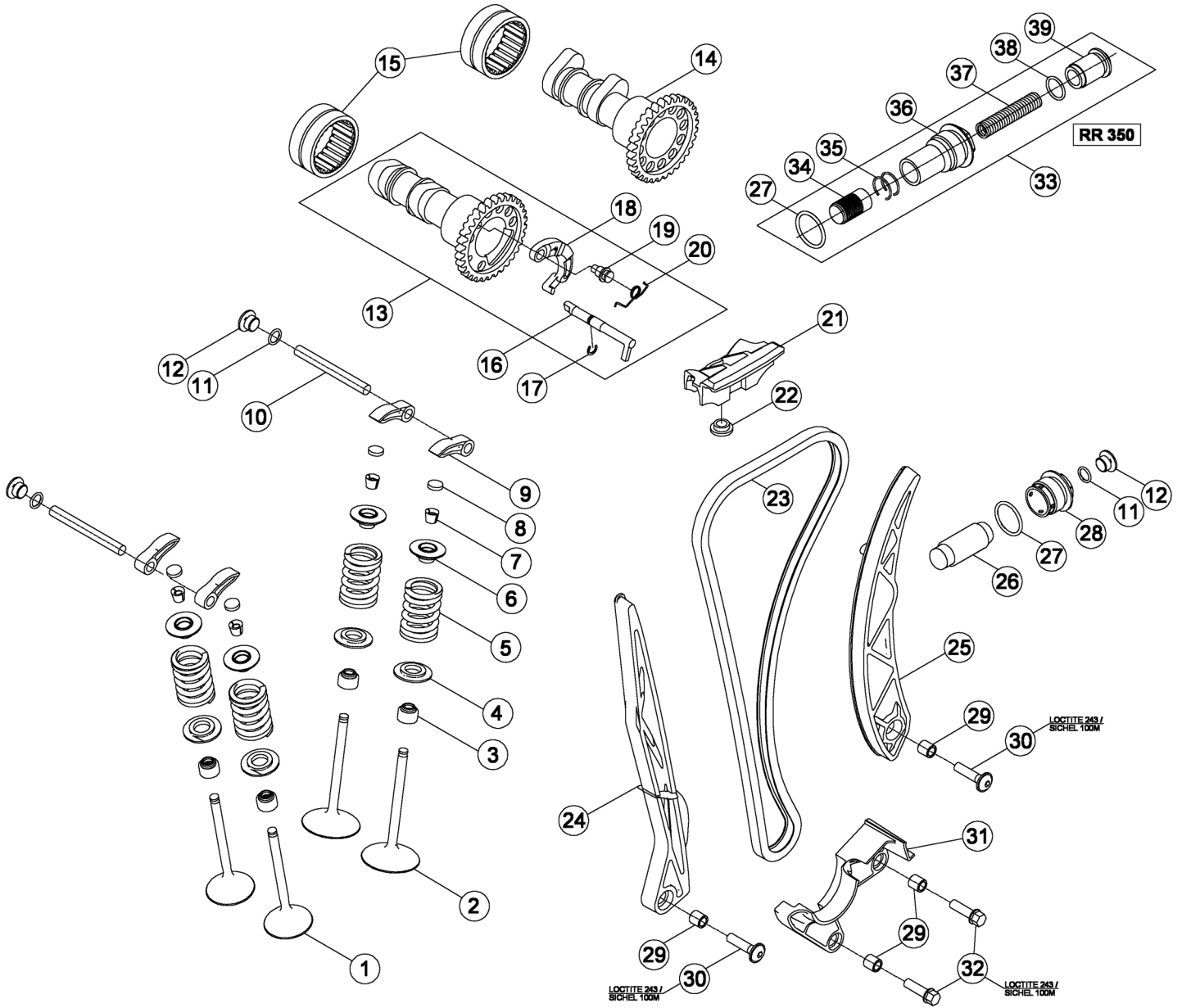

# Tav.14

Pos Loc Pos Ps Pos	Numero Number Numéro Número Nummer	Q.tà Q.ty Q.té M.ge C.ad	Nota Note Note Nota Anm.	Descrizione	Description	Désignation	Beschreibung	Descripcìon
16	006110560 000	1		Albero Di Decompressione	Decompression Shaft	Arbre Decompression	Dekowelle	Ciguenal De Decompression
17	2822635 000	1		Seeger H7	Circlip H7	Circlip H7	Seeger H7	Seeger H7
18	006110550 000	1		Massa decompressore	Decompressor weight	Masse décompression	Masse dekompressor	Masa de descompresión
19	006110570 000	1		Perno	Pin	Pivot	Zapfen	Perno
20	006110580 000	1		Molla decompressione	Decompression spring	Ressort décompresseur	Dekompressionsfeder	Muelle, descompresión
21	006110638 000	1		Pattino fisso	Fixed pad	Patin fixe	Fester Laufschuh	Patin fijo
22	006110660 000	1		Boccola	Bush	Moyeu	Büchse	Buje
23	022110600 000	1	350	Catena distribuzione Z=124	Timing chain Z=124	Chaîne de distribution Z=124	Ventilsteuerkette Z=124	Cadena distribución Z=124
23	006110600 000	1	400-450 520	Catena distribuzione Z=126	Timing chain Z=126	Chaîne de distribution Z=126	Ventilsteuerkette Z=126	Cadena distribución Z=126
24	006110618 000	1		Pattino fisso	Fixed pad	Patin fixe	Fester Laufschuh	Patin fijo
25	022110628 000	1		Pattino mobile completo	Movable guide, assy.	Patin mobile complet	Gleitstück kpl.	Zapata móvil completo
26	006110670 000	1		Tensionatore Catena Trasmissione	Drive Chain Tensioner	El. de Mise en Tension	Antriebskettenspanner	Tensador Catena Transmisión
27	1066466 000	1		Anello OR 20x2	O-Ring 20x2	Bague d'étanchéité 20x2	O-Ring 20x2	Anillo OR 20x2
28	006110688 000	1		Tappo	Plug	Bouchon	Verschluß	Tapón
28	006150070 000	1	FACTORY	Tappo	Plug	Bouchon	Verschluß	Tapón
29	006110650 000	4		Boccola 6,2x9x9	Bush 6,2x9x9	Moyeu 6,2x9x9	Büchse 6,2x9x9	Buje 6,2x9x9
30	3130792 000	2		Vite TBCE 6x25	Screw TBCE 6x25	Vis TBCE 6x25	Schraube TBCE 6x25	Tornillo TBCE 6x25
31	022110648 000	1		Protezione catena completa	Chain protection assy.	Chaîne protection complete	Schutzstück Kette kpl.	Protección cadena completa
32	1149070 000	2		Bullone 6x20 ch rs	Bolt 6x20 ch rs	Boulon 6x20 ch rs	Bolzen 6x20 ch rs	Tornillo 6x20 ch rs
33	006111678 000	1	350	Tendicatena completo	Chain tightener assy.	Tendeur de chaîne complet	Kettenspanner komplett	Tensor de cadena completo
34	006111672 000	1	350	Pistone	Piston	Piston	Kolben	Pistón
35	2823105 000	2	350	Seeger Rb14	Seeger Rb14	Seeger Rb14	Seeger Rb14	Seeger Rb14
36	006111671 000	1	350	Bullone tendicatena	Chain tightener bolt	Boulon tendeur de chaîne	Bolzen Kettenspanner	Tornillo tensor de cadena
37	006111673 000	1	350	Molla tendi catena	Chain tightener spring	Ressort tendeur de chaîne	Feder Kettenspanner	Muelle tensor de cadena
38	1066175 000	1	350	Anello OR 13x1.5	O-Ring 13x1.5	Bague d'étanchéité 13x1.5	O-Ring 13x1.5	Anillo OR 13x1.5
39	006111688 000	1	350	Tappo completo	Complete cap	Bouchon complet	Verschluß komplett	Tapón completo

# Tav.15

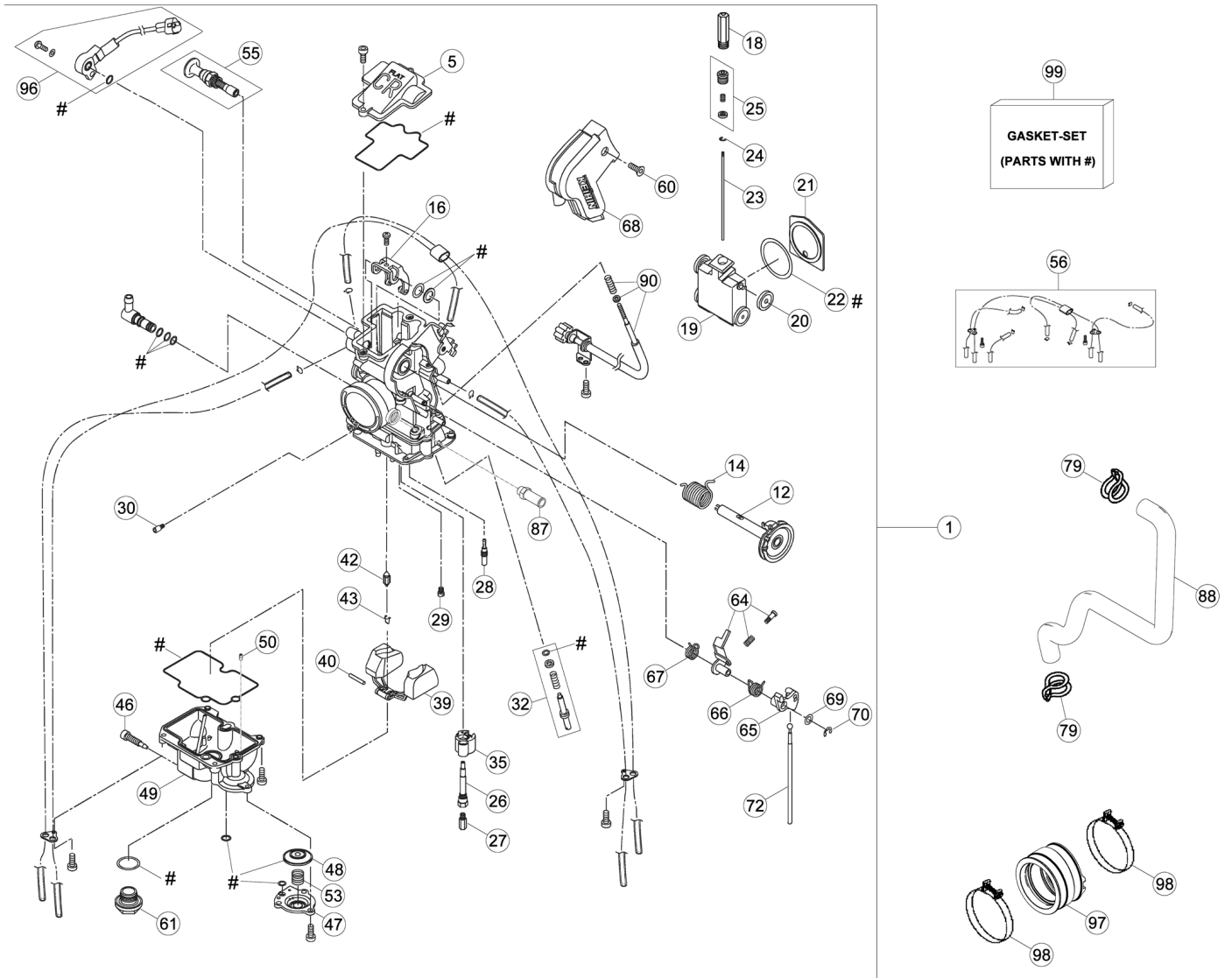

# Tav.15

Pos Loc Pos Ps Pos	Numero Number Numéro Número Nummer	Q.tà Q.ty Q.té M.ge C.ad	Nota Note Note Nota Anm.	Descrizione	Description	Désignation	Beschreibung	Descrìcion
1	006121308 000	1	350	Carburatore	Carburettor	Carburateur	Vergaser	Carburador
1	006121108 000	1	400	Carburatore	Carburettor	Carburateur	Vergaser	Carburador
1	006121408 000	1	400 FACT.	Carburatore	Carburettor	Carburateur	Vergaser	Carburador
1	006120108 000	1	450	Carburatore	Carburettor	Carburateur	Vergaser	Carburador
1	006120408 000	1	450 FACT.	Carburatore	Carburettor	Carburateur	Vergaser	Carburador
1	006122108 000	1	520	Carburatore	Carburettor	Carburateur	Vergaser	Carburador
1	006122408 000	1	520 FACT.	Carburatore	Carburettor	Carburateur	Vergaser	Carburador
5	3625146 000	1		Coperchio carburatore	Carburettor cover	Couvercle carburateur	Abdeckung Vergaser	Tapa carburador
12	3625155 000	1		Albero Completo Valvola	Throttle Shaft Cpl	Arbre Complet Valve	Seilzugrolle	Arbre Completo Valvula
14	3625156 000	1		Molla	Spring	Ressort	Feder	Muelle
16	3625150 000	1		Braccetto Connessione Valvola	Link Arm Throttle Valve	Bras Jonction Valve	Gasschieberarm	Brazo Conexion Valvula
18	3625241 000	1		Distanziale	Spacer	Entretoise	Distanzstück	Distanciadior
19	3625149 000	1		Valvola a farfalla	Throttle valve	Papillon	Ventilklappe	Válvula de mariposa
20	3625249 000	1		Cuscinetto Valvola A Farfalla	Bushing Throttle Valve	Roulement Valve	Lagerrolle Gasschieber	Cojinete Valvula
21	3625151 000	1		Guarnizione Piastra Valvola A Farf.	Gasket, Throttle Valve Plate	Joint Plaque Valve	Dichtpl. Gassch. Fcr-Mx	Junta Placa Valvula
22	3625250 000	1		Rondella Piastra Valvola A Farf.	Washer, Throttle Valve Plate	Rondelle Plaque Valve	Dichtscheibe Gasschieber	Arandela Place Valvula
23	006120010 000	1		Spillo "OBDTS"	Needle "OBDTS"	Pointeau "OBDTS"	Düsenadel "OBDTS"	Aguja "OBDTS"
23	3625239 000	1		Spillo "OBDVT"	Needle "OBDVT"	Pointeau "OBDVT"	Düsenadel "OBDVT"	Aguja "OBDVT"
23	3625248 000	1		Spillo "OBDTR"	Needle "OBDTR"	Pointeau "OBDTR"	Düsenadel "OBDTR"	Aguja "OBDTR"
23	3625420 000	1		Spillo "OBDVR"	Needle "OBDVR"	Pointeau "OBDVR"	Düsenadel "OBDVR"	Aguja "OBDVR"
23	3625491 000	1		Spillo "OBDVS"	Needle "OBDVS"	Pointeau "OBDVS"	Düsenadel "OBDVS"	Aguja "OBDVS"
23	3625148 000	1		Spillo "OBEKT"	Needle "OBEKT"	Pointeau "OBEKT"	Düsenadel "OBEKT"	Aguja "OBEKT"
23	3625244 000	1		Spillo "OBETP"	Needle "OBETP"	Pointeau "OBETP"	Düsenadel "OBETP"	Aguja "OBETP"
23	3625245 000	1		Spillo "OBETQ"	Needle "OBETQ"	Pointeau "OBETQ"	Düsenadel "OBETQ"	Aguja "OBETQ"
23	006120110 000	1		Spillo "OBETR"	Needle "OBETR"	Pointeau "OBETR"	Düsenadel "OBETR"	Aguja "OBETR"
23	006120120 000	1		Spillo "OBETS"	Needle "OBETS"	Pointeau "OBETS"	Düsenadel "OBETS"	Aguja "OBETS"
23	006120130 000	1		Spillo "NCVQ"	Needle "NCVQ"	Pointeau "NCVQ"	Düsenadel "NCVQ"	Aguja "NCVQ"
24	3625240 000	1		Anello Fissaggio Spillo	Bar Clip	Bague Fixage Epingle	Nadelclip	Anillo Fijacion Aguja
25	3625147 000	1		Kit Viti Fissaggio Spillo	Needle Set Screw	Jeu Vis Fixage Epingle	Nadelschraube	Juego Tornillos Fijacion Aguja
26	3625256 000	1		Sede spillo	Needle seat	Siège de l'aiguille	Nadelsitz	Asiento del obturador
27	3625107 000	1	162	Getto massimo	Main jet	Gicleur maxi	Hauptdüse	Surtidor máximo
27	3625108 000	1	165	Getto massimo	Main jet	Gicleur maxi	Hauptdüse	Surtidor máximo
27	3625109 000	1	168	Getto massimo	Main jet	Gicleur maxi	Hauptdüse	Surtidor máximo
27	3625110 000	1	170	Getto massimo	Main jet	Gicleur maxi	Hauptdüse	Surtidor máximo
27	3625111 000	1	172	Getto massimo	Main jet	Gicleur maxi	Hauptdüse	Surtidor máximo
27	3625112 000	1	175	Getto massimo	Main jet	Gicleur maxi	Hauptdüse	Surtidor máximo
27	3625113 000	1	178	Getto massimo	Main jet	Gicleur maxi	Hauptdüse	Surtidor máximo
27	3625114 000	1	180	Getto massimo	Main jet	Gicleur maxi	Hauptdüse	Surtidor máximo
27	3625115 000	1	182	Getto massimo	Main jet	Gicleur maxi	Hauptdüse	Surtidor máximo
27	3625116 000	1	185	Getto massimo	Main jet	Gicleur maxi	Hauptdüse	Surtidor máximo
27	3625117 000	1	188	Getto massimo	Main jet	Gicleur maxi	Hauptdüse	Surtidor máximo
27	3625118 000	1	190	Getto massimo	Main jet	Gicleur maxi	Hauptdüse	Surtidor máximo
28	1642355 000	1	38	Getto minimo	Starter jet	Gicleur starter	Starterdüse	Surtidor starter
28	3625101 000	1	40	Getto minimo	Starter jet	Gicleur starter	Starterdüse	Surtidor starter
28	1642347 000	1	42	Getto minimo	Starter jet	Gicleur starter	Starterdüse	Surtidor starter
28	1642349 000	1	45	Getto minimo	Starter jet	Gicleur starter	Starterdüse	Surtidor starter
28	1642348 000	1	48	Getto minimo	Starter jet	Gicleur starter	Starterdüse	Surtidor starter
29	3625253 000	1	85	Getto starter	Starter jet	Gicleur starter	Starterdüse	Surtidor starter
30	3625139 000	1	100	Getto aria	Air jet	Gicleur d'air	Luftdüse	Surtidor de aire
32	3625237 000	1		Gruppo vite regolazione miscela	Mixture adjustment screw unit	Gr. de vis de réglage du mélange	Gruppe Gemischregulierschraube	Grupo tornillo de regulación mezcla
35	3625166 000	1		Piastra	Plate	Plaque	Platte	Chapa
39	3625141 000	1		Galleggiante	Float	Flotteur	Schwimmer	Flotador
40	3625140 000	1		Perno per Galleggiante	Arm Pin Float	Pivot Flottant Carburateur	Stift Schwimmer	Eje Flotante
42	006120080 000	1		Valvola a spillo	Needle valve	Soupape à pointeau	Nadelventil	Válvula de aguja
43	006120090 000	1		Fascetta	Clamp	Collier	Schelle	Abrazadera
46	3625170 000	1		Vite Galleggiante Spec.	Drain Screw Float Chamber	Vis Flottant Spec.	Ablassschraube Schwimmergeh.	Tornillo Flotante Espec.
47	3625161 000	1		Coperchio Pompa Accelerat.	Cover Accelerator Pump	Couvercle Pompe Acc.	Gehäuse Beschleunigerpumpe	Tapa Bomba Acelerador
48	006120100 000	1		Membrana	Diaphragm	Membrane	Membrane	Membrana
49	3625142 000	1		Camera Galleggiante	Float Chamber	Flottant Carburateur	Schwimmergehäuse	Camra Flotante
50	006120020 000	1	40	Getto di scarico	Leak jet	Leak jet	Beschleunigerdüse	Valvula de descarga
50	006120030 000	1	50	Getto di scarico	Leak jet	Leak jet	Beschleunigerdüse	Valvula de descarga
50	006120040 000	1	60	Getto di scarico	Leak jet	Leak jet	Beschleunigerdüse	Valvula de descarga
50	006120070 000	1	CLOSED	Getto di scarico	Leak jet	Leak jet	Beschleunigerdüse	Valvula de descarga
53	3625254 000	1		Molla Pompa	Coil Spring	Ressort Pompe	Druckfeder	Muelle Bomba
55	3625157 000	1		Valvola Starter Completa	Starter Valve Cpl.	Valve Cpl Carburateur	Kaltstartbetätigung Kpl.	Valvula Starter Completa

# Tav.15

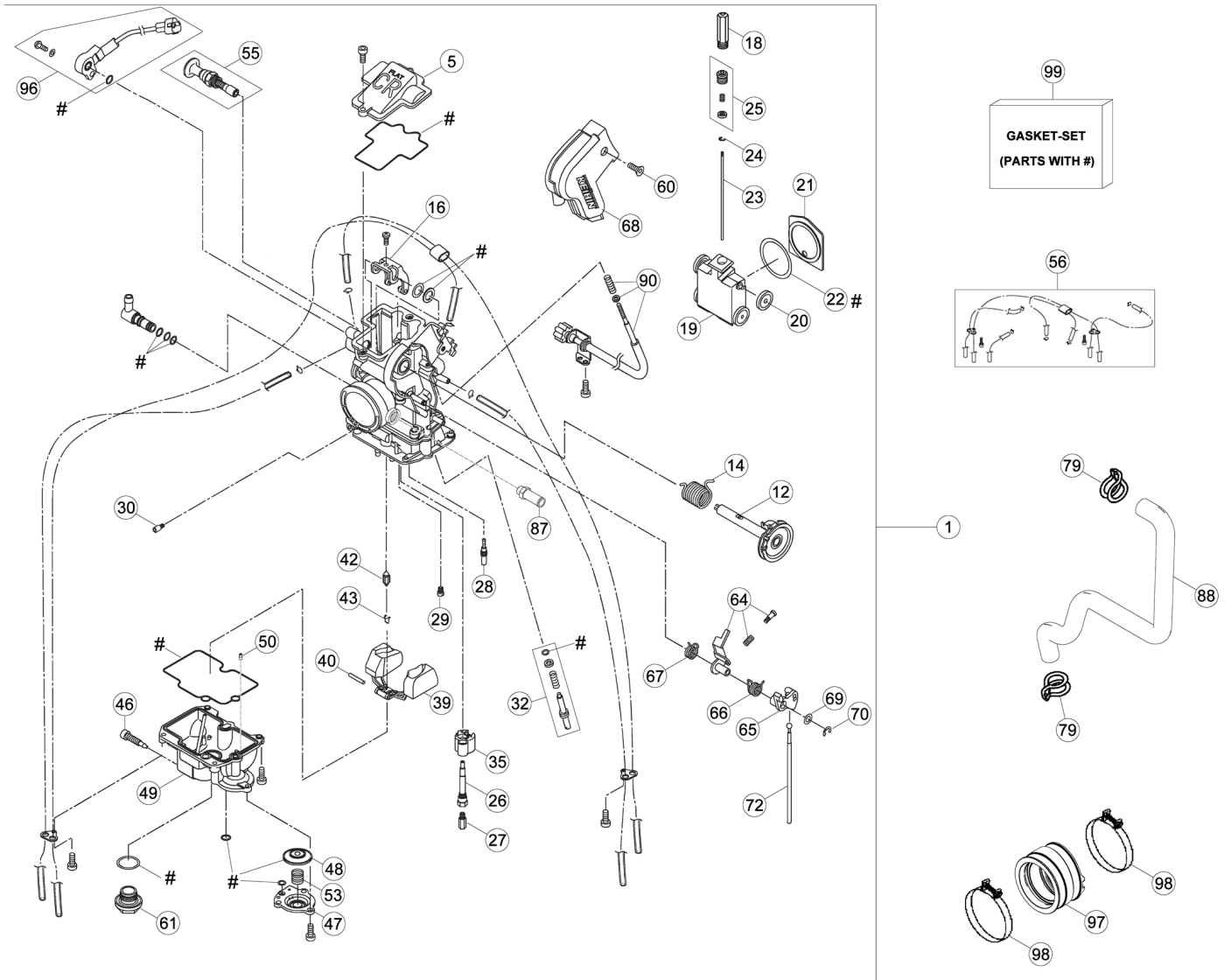



# Tav.15

Pos Loc Pos Ps Pos	Numero Number Numéro Número Nummer	Q.tà Q.ty Q.té M.ge C.ad	Nota Note Note Nota Anm.	Descrizione	Description	Désignation	Beschreibung	Descripcìon
56	3625168 000	1		Tubi Con Piastr. Fcr Compl.	Breath Hose Fcr-Mx Cpl.	Tubes A/Plaqueete Fcr Compl.	Entl.Schl. Fcr-Mx	Tubos Con Placa Completo
60	3625154 000	1		Vite	Screw	Vis	Schraube	Tornillo
61	3625143 000	1		Tappo Vaschetta Livello Benz.	Holding Bolt	Bouchon Cuvette Niveau Ess.	Verschlusschraube	Tapon Deposito Nivel Gasolina
64	3625163 000	1		Leva Interm. Completa	Intermediate Lever Cpl	Levier Complete	Verbindungshebel Kpl.	Palanca Completa
65	3625159 000	1		Connessione Leva	Link Lever	Jonction Levier	Anlenkhebel	Conexion Palanca
66	006120040 000	1		Molla Connes. Leva	Spring Link Lever	Ressort Levier	Feder Anlenkhebel	Muelle Conexion Palanca
67	3625171 000	1		Molla Interm. Leva	Spring Intermediate Lever	Ressort Levier	Feder Verbindungshebel	Muelle Palanca
68	3625153 000	1		Coperchio Cablaggio	Carburetor Cover	Couvercle Cablage	Vergaser Abdeckung	Tapa Carburador
69	3625167 000	1		Rondella Connetore Leva	Washer Link Lever	Rondelle Connecteur Levier	Scheibe Anlenkhebel	Arandela Conector Palanca
70	3625165 000	1		Anello seeger	Snap ring	Circlips	Seegerring	Anillo seeger
72	3625162 000	1		Asta Pompa Acceleratore	Rod Accelerator Pump	Etrier Pompe Acc.	Gestänge Beschleunigerpumpe	Asta Bomba Acelerador
79	1067470 000	2		Anello stringitubo	Pipe clamping ring	Anneau serre-tube	Schlauchschele	Anillo prensatubo
87	006120850 000	1		Raccordo Carburatore	Carburettor Union	Raccord Carburateur	Vergaseranschluss	Empalme Carburador
88	006120900 000	1		Tubo sfiato	Breather tube	Tuyau réinflard	Entlüftungsleitung	Tubo respiradero
90	3625145 000	1		Kit Viti Stop	Stop Screw Kit	Jeu Vis Stop	Stellschraube Kpl.	Juego Tornillos Stop
96	3625255 000	1		Sensore Posizione Valvola A Farfalla	Throttle Position Sensor	Sensor Position Valve	Sensor Gasschieberposition	Sensor Valvula
97	020380300 000	1		Manicotto carburatore	Manifold carburettor	Manchon carburateur	Muffe Vergaser	Manguito carburador
98	1514607 800	2		Fascetta	Clamp	Collier	Schelle	Abrazadera
99	3625169 000	1		Kit guarnizioni	Packings kit	Jeu joints	Dichtungenssatz	Grupo juntas

# Tav.16

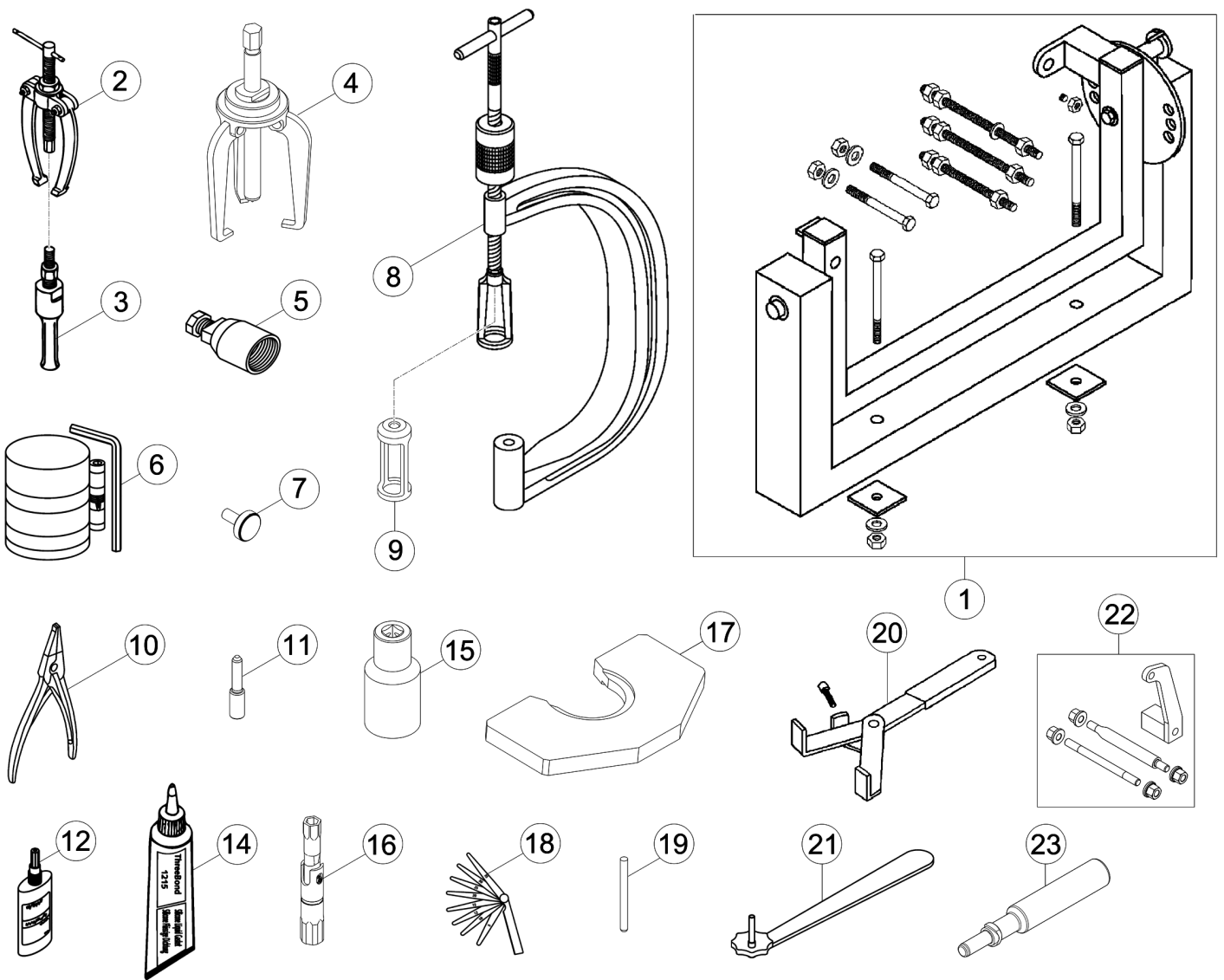

# Tav.16

Pos Loc Ps Pos	Numero Number Numéro Número Nummer	Q.tà Q.ty Q.té M.ge C.ad	Nota Note Note Nota Anm.	Descrizione	Description	Désignation	Beschreibung	Descrìcion
1	3625132 000	1		Attrezzatura Mont. Motore	Mounting Rack	Outils Montage Moteur	Montagebock	Aparejos Montaje Motor
2	3625081 000	1		Estrattore	Extractor	Extracteur	Abziehvorricht	Extractor
3	006140160 000	1		Estrattore Cuscinetti Interni 20-30MM	Intern. Bearings Puller 20-30MM	Extracteur Roulements Int. 20-30MM	Einsatz 20-30MM	Extractor Cojinetes Int. 20-30MM
4	006140150 000	1		Estrattore Per Ingranaggi	Extractor For Timing Gear	Extracteur Engranages	Zweiback.Abzieher Steuerritzel	Extractor Engranajes
5	3625173 000	1		Estrattore volante	Flywheel extractor	Extracteur pour volant	Auszieher für Schwungrad	Extractor volante
6	006140170 000	1		Serie fasce elastiche	Piston ring set	Jeu de segments piston	Satz kolbenring	Juego de aros de piston
7	006140050 000	1		Attrezzo sbloccaggio tendicatena	Chain tightener unlocking tool	Deverrouillage tend. de ch.	Entriegelung Kettenspanner	Desenclavamiento tens. de cad.
8	0100043 000	1		Attrezzo mont.- smont. valvole	Valves ass. and rem. tool	Outil pour mont. dem. soup.	Werkzeug für Ventilmontage	Ut. montaje- desm. válvulas
9	006140030 000	1		Attrezzo per montaggio molle valvola	Valvespring fitting tool	Outil pour montage des ressorts de soupape	Montagewerkzeug für ventillfedern	Utensilio para el montaje del muelle de la válvula
10	3625097 000	1		Pinza Speciale Anelli	Special Circlip Plier	Pince Speciale Bagues	Seegerringzange Verkehrt	Pinza Especial Anillos
11	006140110 000	1		Attrezzo per bloccaggio albero motore al PMS	Tool to hold crankshaft in TDC position	Util d'immobilisation du vilebrequin au PMH	Werkzeug für Kurbelwellenblockierung am OT	Herramienta para bloqueo cigüeñal al PMS
12	3625001 000	1		Loctite 243 50ML	Loctite 243 50ML	Loctite 243 50ML	Loctite 243 50ML	Loctite 243 50ML
14	3625000 000	1		Silicone	Silicon Gasket	Silicon	Silikondichtmass	Silicon
15	006140020 000	1		Chiave a bussola 36MM	Socket wrench 36MM	Cle à douille 36MM	Schlusseinsatz 36MM	Llave de enchufe 36MM
16	020440100 000	1		Chiave candela	Ignition wrench	Clé à bougie	Zündkerzenschlüssel	Llave bují
17	006140070 000	1		Attrezzo smontaggio biella	Conn.-rod dismantling Tool	Outil de démontage bielle	Demontagewerkzeug Pleuel	Herramientas desmontaje biela
18	006140210 000	1		Calibro per gioco valvole	Valve allowance gauge	Calibre jeu soupapes	Lehre Ventilspiel	Calibre para juego de válvulas
19	006140180 000	1		Calibro differenziale guida valvola	Valve guide gauge	Guide soupape	Lehre Ventilführung	Calibre para guía válvula
20	006140040 000	1		Chiave di fermo mozzo frizione	Clutch hub retaining wrench	Cléf d'arret moyeau embrayage	Halterungsschlüssel der Kupplungsnahe	Llave bloquear cubo fricción
21	006140200 000	1		Chiave vite regolazione miscela	Mixture adjustment screw wrench	Clé de vis de réglage du mélange	Schlüssel Gemischregulierschraube	Llave tornillo de regulación mezcla
22	006140140 000	1		Fissaggi motore	Engine fasteners	Fixations moteur	Motorbefest.	Fijaciones motor
23	022140200 000	1	350	Attrezzo anello elastico spinotto	Piston pin circlip tool	Outil pour bague él axe de piston	Werkzeug für sprengring zur Bolzenfeststellung	Ut. anillo elástico bloquea-clavija
23	006140300 000	1	400-450 520	Attrezzo anello elastico spinotto	Piston pin circlip tool	Outil pour bague él axe de piston	Werkzeug für sprengring zur Bolzenfeststellung	Ut. anillo elástico bloquea-clavija

# Tav.17

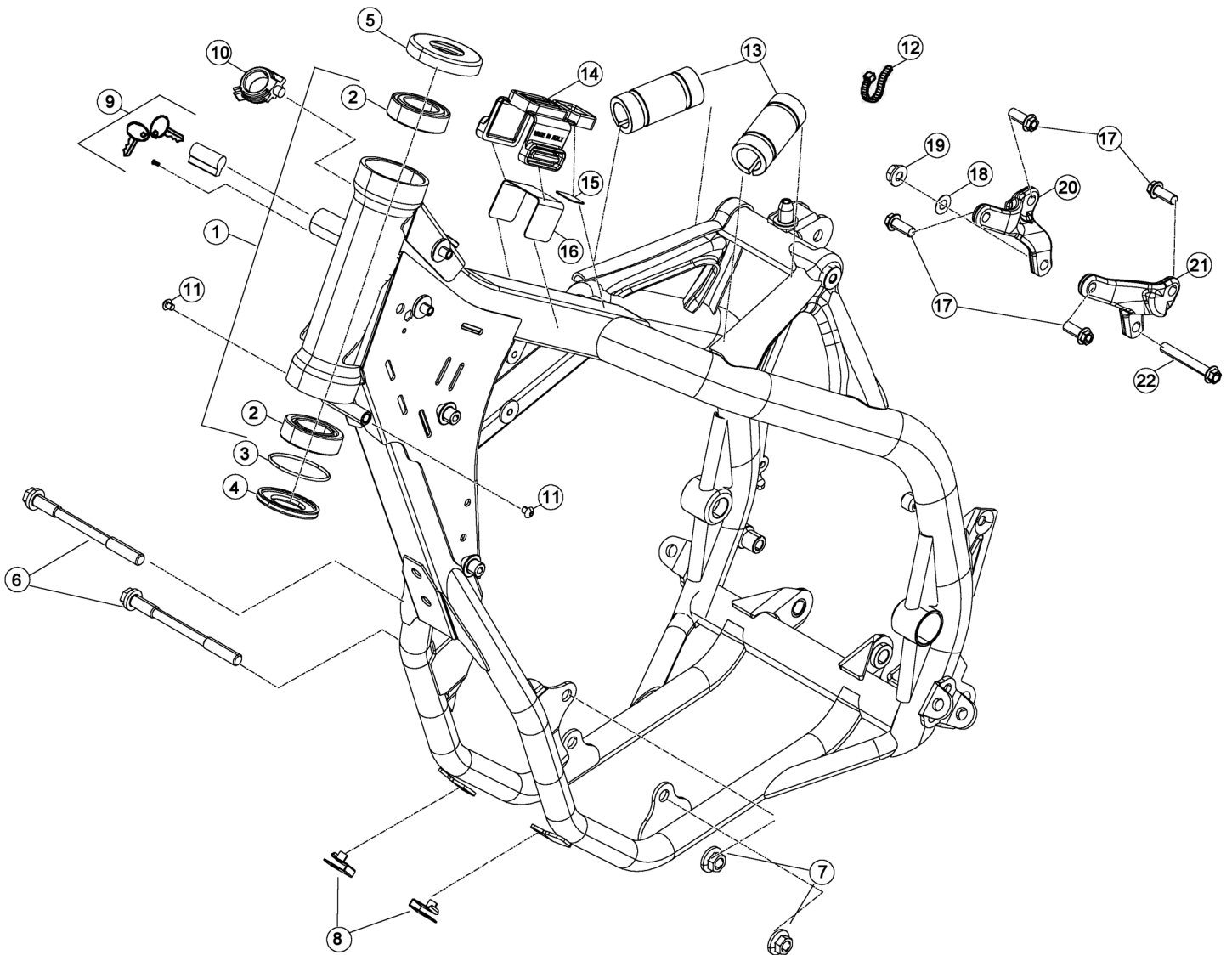

**Beta**  
the play bike

# Tav.17

Pos Loc Pos Ps Pos	Numero Number Numéro Número Nummer	Q.tà Q.ty Q.té M.ge C.ad	Nota Note Note Nota Anm.	Descrizione	Description	Désignation	Beschreibung	Descripcìon
1	020310008 053	1		Telaio completo	Frame, assy	Chassis complet	Rahmen, kpl	Bastidor compl.
2	1299510 000	2		Cuscinetto conico 29x50x15	Conical bearing 29x50x15	Roulement conique 29x50x15	Lager 29x50x15	Cojinete conico 29x50x15
3	1066935 000	1		Anello OR	O-Ring	Bague d'étanchéité	O-Ring	Anillo OR
4	1067535 000	1		Anello parapolvere	Dust cover	Disque pare-poussière	Staubdeckel	Disco gurdapolvere
5	2598782 000	1		Protezione cuscinetto	End Cap Bearing	Palier De Bielle	Lagerdeckel	Tapa Rodamiento
6	1164607 000	2		Perno motore	Engine pin	Axe moteur	Motorbolzen	Perno motor
7	1321050 000	2		Dado flangiato M10X1,25	Flanged nut M10X1,25	Ecrou bordé M10X1,25	Flanschmutter M10X1,25	Tuerca embreadada M10X1,25
8	2560311 000	2		Piastrina elastica M6	Spring plate M6	Plaquette élastique M6	Plättchen M6	Pletina elástica M6
9	2885861 000	1		Serratura bloccasterzo	Security lock	Serrure blocage guidon	Lenkradschloss	Cerradura bloque manillar
10	2524444 000	1		Passacavo	Grommet	Passe-câble	Kabeldurchgang	Pasacables
11	3164018 000	2		Vite M8X10	Screw M8X10	Vis M8X10	Schraube M8X10	Tornillo M8X10
12	1514264 000	1		Fascetta	Clamp	Collier	Schelle	Abrazadera
13	020310370 000	2		Tampone posteriore serbatoio	Rear buffer tank	Silentbloc AR. réservoir	Puffer tank	Silent-block tras. deposito
14	020310330 000	1		Tampone anteriore serbatoio	Front buffer tank	Silentbloc AV. réservoir	Puffer tank	Silent-block del. deposito
15	020310340 000	1		Adesivo anteriore	Front sticker	Décalcomanie AV.	Vorderer Kleber	Pega delantero
16	020310350 000	1		Adesivo posteriore	Rear sticker	Décalcomanie AR.	Hinterer Kleber	Pega trasero
17	1154492 000	4		Vite M8X20	Screw M8X20	Vis M8X20	Schraube M8X20	Tornillo M8X20
18	2749500 000	1		Rondella	Washer	Rondelle	U.Scheibe	Arandela
19	1317120 000	1		Dado M8	Nut M8	Ecrou M8	Mutter M8	Tuerca M8
20	020311440 000	1	350	Staffa fiss. testa dx.	R.H. cylinder head sec. Bracket	Bride fix. Culasse D.	Kopfbefestigungshalterung R.	Brida fij. culata der.
20	020310440 000	1	400-450 520	Staffa fiss. testa dx.	R.H. cylinder head sec. Bracket	Bride fix. Culasse D.	Kopfbefestigungshalterung R.	Brida fij. culata der.
21	020311450 000	1	350	Staffa fiss. testa sx.	L.H. cylinder head sec. Bracket	Bride fix. Culasse G.	Kopfbefestigungshalterung L.	Brida fij. culata izq.
21	020310450 000	1	400-450 520	Staffa fiss. testa sx.	L.H. cylinder head sec. Bracket	Bride fix. Culasse G.	Kopfbefestigungshalterung L.	Brida fij. culata izq.
22	1155970 000	1		Bullone M8x65	Bolt M8x65	Boulon M8x65	Bolzen M8x65	Tornillo M8x65

# Tav.18

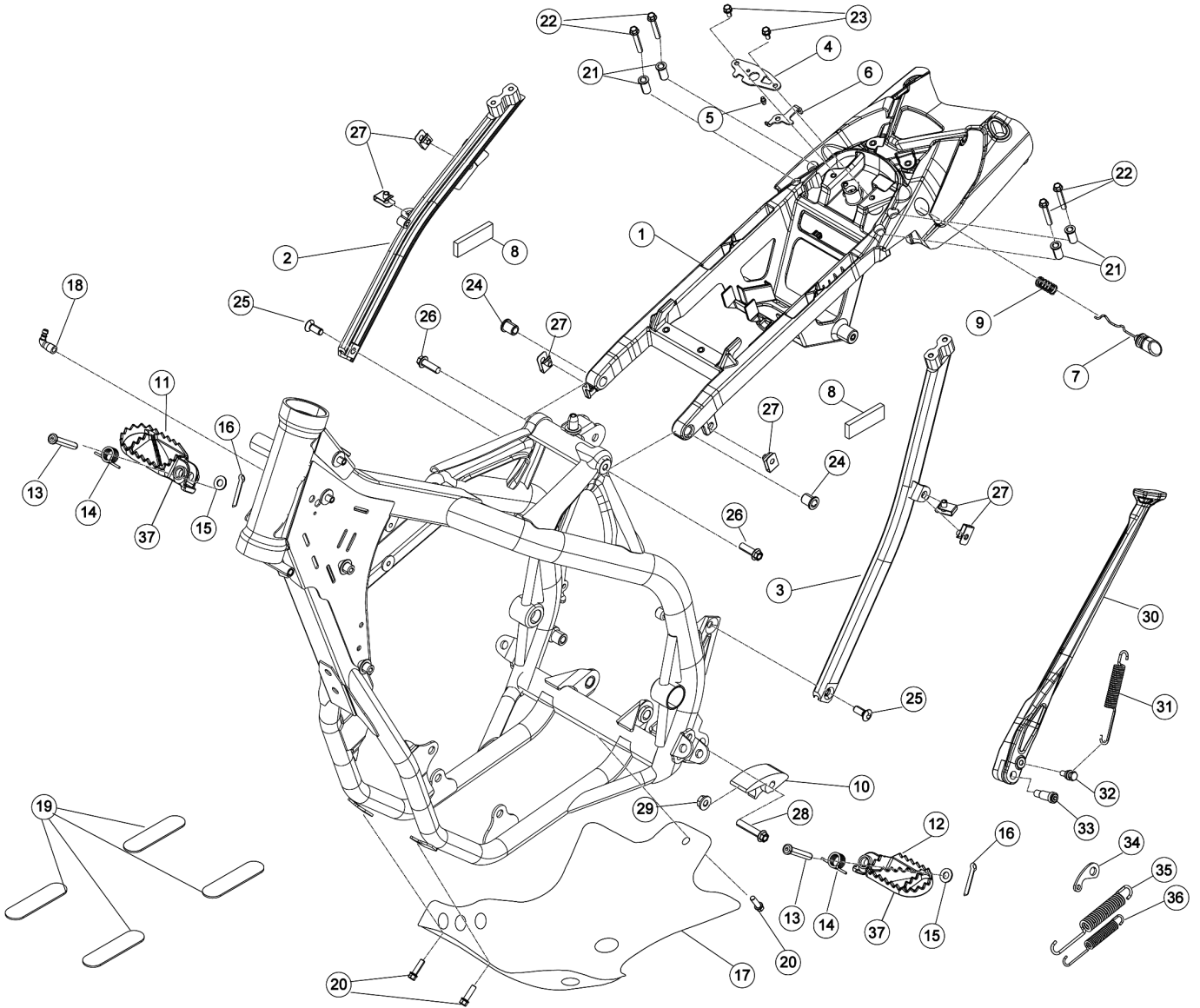

**Beta**  
the play bike

# Tav.18

Pos Loc Pos Ps Pos	Numero Number Numéro Número Nummer	Q.tà Q.ty Q.té M.ge C.ad	Nota Note Note Nota Anm.	Descrizione	Description	Désignation	Beschreibung	Descripción
1	020321021 059	1		Telaietto	Frame	Châssis	Kleiner Rahmen	Chasis
2	020320000 059	1		Puntone Dx	RH strut	Etrésillon droit	Strebe, rechts	Puntal der.
3	020320010 059	1		Puntone Sx	LH strut	Etrésillon gauche	Strebe, links	Puntal Izq.
4	020320100 005	1		Piastra fissaggio serratura	Lock sec. Plate	Plaque fix. Serrure	Befestigungsplatte Schloß	Chapa fij. cerradura
5	020321120 000	1		Perno serratura	Pin	Pivot	Zapfen	Perno
6	020320110 005	1		Piastra ritegno serratura	Plate	Plaquette	Schild	Placa
7	020320138 000	1		Bottone	Knob	Bouton	Knopf	Boton
8	020320070 000	2		Tampone	Buffer	Silentbloc	Puffer	Silent-block
9	020320160 000	1		Molla	Spring	Ressort	Feder	Muelle
10	2525601 000	1		Pattino catena	Chain shoe	Doigt chaine	Gleitauflage	Patin cadena
11	2532521 000	1		Pedana dx.	Rubber mat R.H.	Tapis d.	Fußblech rechts	Estribo der.
12	2532531 000	1		Pedana sx.	Rubber mat L.H.	Tapis g.	Fußblech links	Estribo izq.
13	2554465 000	2		Perno pedana	Footrest pin	Pivot repose-pied	Rasten Pin	Eje estribera
14	016320200 000	2		Molla pedanina	Foot rest spring	Ressort repose-pied	Fußblechfeder	Muelle estribo
15	2754000 000	2		Rondella 10x21x2	Washer 10x21x2	Rondelle 10x21x2	Scheibe 10x21x2	Arandela 10x21x2
16	1281993 000	2		Copiglia 3x20	Split pin 3x20	Goupille 3x20	Splint 3x20	Grupilla 3x20
17	020320200 000	1		Protezione motore	Engine protection	Protection moteur	Motorschutz	Protección motor
17	020320600 000	1	FACTORY	Protezione motore carbonio	Engine protection carbon	Protection moteur carbone	Motorschutz karbon	Protección motor carbono
18	2723470 000	1		Raccordo per sfiato	Breather pipe	Raccord pour vidange	Entlüftungsrohranschluß	Racor para ventilación
19	2910317 000	4		Tampone	Buffer	Silentbloc	Puffer	Silent-block
20	1149070 000	3		Bullone 6x20 ch rs	Bolt 6x20 ch rs	Boulon 6x20 ch rs	Bolzen 6x20 ch rs	Tornillo 6x20 ch rs
21	020320040 000	4		Boccola superiore	Upper bush	Douille supérieure	Obere Buchse	Casquillo superior
22	1150355 000	4		Bullone M6x35	Bolt M6x35	Boulon M6x35	Bolzen M6x35	Tornillo M6x35
23	1146251 000	2		Bullone flangiato M5x12	Head Flanged bolt M5x12	Boulon Bridé M5x12	Bundbolzen M5x12	Bulón con Brida M5x12
24	020320030 000	2		Boccola anteriore	Front bush	Douille avant	Vordere Buchse	Casquillo delantero
25	007320320 000	2		Vite speciale TSBEI M8x20	Special screw TSBEI M8x20	Vis spéciale TSBEI M8x20	Spezialschraube TSBEI M8x20	Tornillo especial TSBEI M8x20
26	3164070 000	2		Vite flangiata 8x30	Flanged screw 8x30	Vis à brides 8x30	Flanschschraube 8x30	Tornillo rebordeado 8x30
27	2560311 000	6		Piastrina elastica M6	Spring plate M6	Plaquette élastique M6	Plättchen M6	Pletina elástica M6
28	1155480 000	1		Vite M8x40	Screw M8x40	Vis M8x40	Schraube M8x40	Tornillo M8x40
29	1317020 000	1		Dado autoblocc. Basso M8	Nut M8	Ecrou M8	Mutter M8	Tuerca M8
30	1239899 000	1		Cavalletto	Central stand	Béquille	Kippständer	Caballette
31	020320260 000	1		Molla cavalletto	Central stand spring	Ressort béquille	Feder Kippständer	Muelle caballete
32	1166615 000	1		Bullone spec. piastra cavalletto	Central stand special bolt	Boulon spec. plaque béq.	Spezialschraube Kippständerplatte	Tornillo especial chapa caballete
33	1166614 000	1		Bullone spec. cavalletto	Special bolt	Boulon spec.	Spezialschraube	Tornillo especial
34	2557636 000	1		Piastrina aggancio molla	Bracket spring	Plaquette accroch. ressort	Plättchen federanlenkung	Placa eng. muelle
35	2248819 000	1		Molla esterna	Spring	Ressort	Feder	Muelle
36	2248818 000	1		Molla interna	Spring	Ressort	Feder	Muelle
37	2532537 000	1	FACTORY	Coppia pedane poggiapiedi	Foot-pegs, pair	Couple repose-pieds	Pedalpaar	Par de estribos

# Tav.19

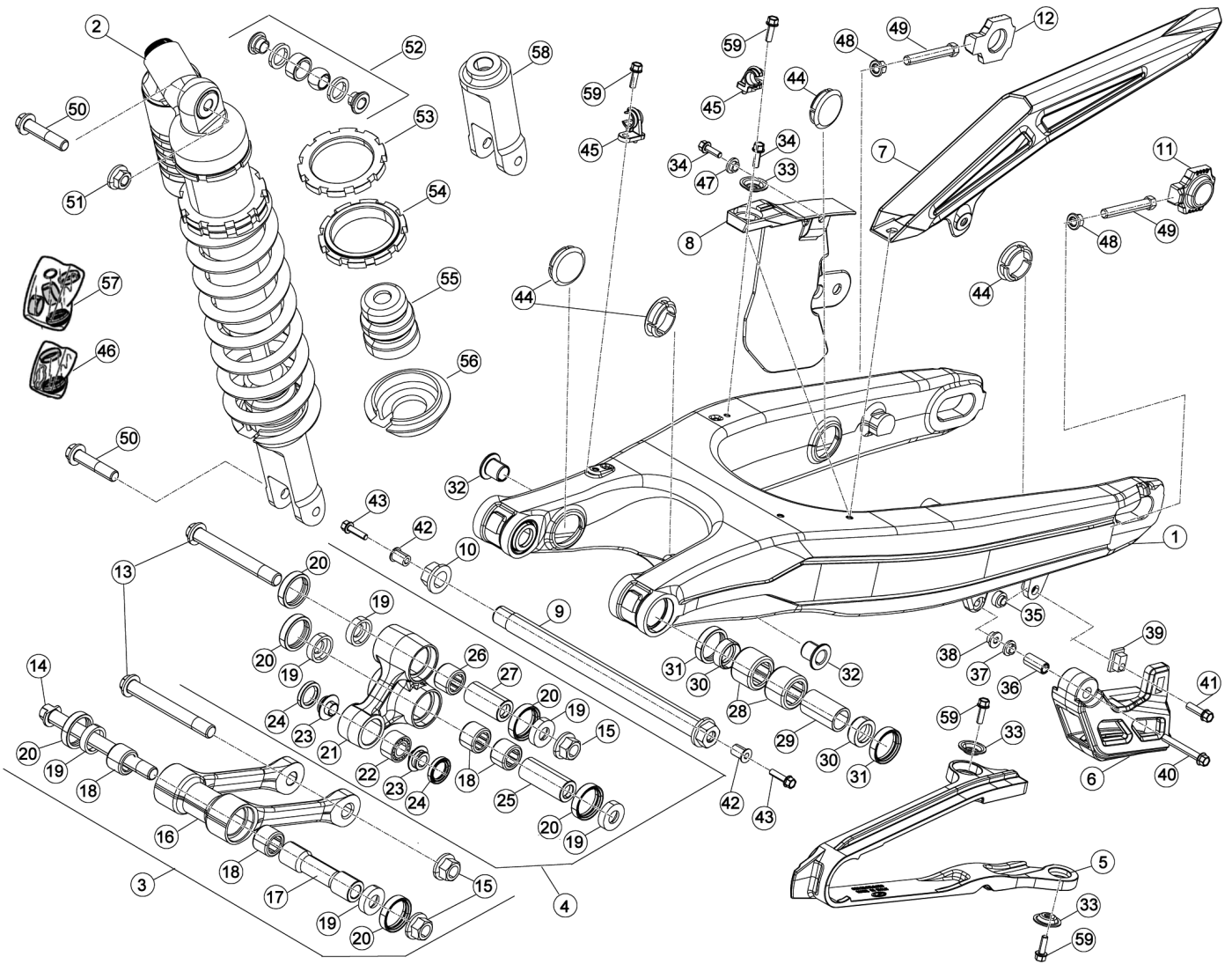





# Tav.19

Pos Loc Pos Ps Pos	Numero Number Numéro Número Nummer	Q.tà Q.ty Q.té M.ge C.ad	Nota Note Note Nota Anm.	Descrizione	Description	Désignation	Beschreibung	Descripcìon
1	020330000 000	1		Forcellone	Big fork	Fourche	Radschwinge	Horquilla
2	020331400 000	1		Ammortizzatore	Damper	Amortisseur	Stoßdämpfer	Amortiguador
3	020330308 000	1		Bielleffa	Biellette	Connecting rod	Bolzensange	Bielefa
4	020330208 000	1		Bilanciere	Lever	Balancier	Kipphebel	Balancin
5	020330150 000	1		Tassello guidacatena super.	Upper sliding block	Cheville guide de chaine sup.	Schwingschleifklotz oben	Protector cadena superior
6	2910071 000	1		Tassello guidacatena infer.	Lower sliding block	Cheville guide de chaine inf.	Schwingschleifklotz unten	Protector cadena inferior
7	1288591 159	1		Copricatena superiore	Up. Chain cover	Couvre-chaine superieur	Kettenschutz oben	Cubrecadena superior
8	1288594 159	1		Copricatena inferiore	Lower chain cover	Couvre-chaine inferieur	Kettenschutz unten	Cubrecadena inferior
9	2547652 000	1		Perno forcellone	Swingarm pivot	Axe fourche AR.	Schwingbolzen	Eje basculante
10	1327121 000	1		Dado speciale	Special nut	Ecrou spéciale	Spezialmutter	Tuerca especial
11	2911866 100	1		Tendicatena SX	Chain adjuster L.	Tendeur de chaine G.	Kettenspanne L.	Tensor de cadena I.
12	2911865 100	1		Tendicatena DX	Chain adjuster R.	Tendeur de chaine D.	Kettenspanner R.	Tensor de cadena D.
13	1163992 000	2		Vite speciale M12	Special screw M12	Vis spéciale M12	Spezialschraube M12	Tornillo especial M12
14	020330320 000	1		Vite speciale M12	Special screw M12	Vis spéciale M12	Spezialschraube M12	Tornillo especial M12
15	1321130 000	3		Dado autobloccante M12	Self locking nut M12	Ecrou de sécurité M12	Mutter, selbstsichernd M12	Tuerca de seguridad M12
16	020330300 000	1		Bielleffa	Biellette	Connecting rod	Bolzensange	Bielefa
17	020330310 000	1		Distanziale	Spacer	Entretoise	Distanzstück	Distanciadador
18	1122055 000	4		Boccola a rulli 20x26x16	Roller bearing 20x26x16	Douille à roulements 20x26x16	Rollenbuchse 20x26x16	Caja de grasa de rodillos 20x26x16
19	2814083 000	6		Scodellino	Stop washer	Rondelle d'ar	Federaufnahme	Platillo
20	1064481 000	6		Paraolio	Oil seal	Pare-huile	Dichtring	Sello de lub.
21	020330200 000	1		Bilanciere	Lever	Balancier	Kipphebel	Balancin
22	1617310 000	1		Boccola a rulli 12x24x30	Roller bearing 12x24x30	Douille à roulements 12x24x30	Rollenbuchse 12x24x30	Caja de grasa de rodillos 12x24x30
23	1121920 000	2		Boccola	Bush	Moyeu	Büchse	Buje
24	1056020 000	2		Paraolio 16x24x4	Oil seal 16x24x4	Pare-huile 16x24x4	Dichtring 16x24x4	Sello de lub. 16x24x4
25	1362813 000	1		Distanziale 12x20x50	Spacer 12x20x50	Entretoise 12x20x50	Distanzstück 12x20x50	Distanciadador 12x20x50
26	1122061 000	1		Boccola a rulli 20x26x30	Roller bearing 20x26x30	Douille à roulements 20x26x30	Rollenbuchse 20x26x30	Caja de grasa de rodillos 20x26x30
27	1362812 000	1		Distanziale 12x20x40	Spacer 12x20x40	Entretoise 12x20x40	Distanzstück 12x20x40	Distanciadador 12x20x40
28	1122056 000	4		Boccola a rullini 22x28x12	Roller cage 22x28x12	Cage Aiguille 22x28x12	Rollenkäfig 22x28x12	Jaula rodillos 22x28x12
29	1349183 000	2		Distanziale forcellone	Big fork spacer	Entretoise fourche	Distanzstück Radschwinge	Distanciadador horquilla
30	2814081 000	4		Scodellino	Stop washer	Rondelle d'ar	Federaufnahme	Platillo
31	1064481 000	4		Paraolio	Oil seal	Pare-huile	Dichtring	Sello de lub.
32	020330010 000	2		Boccola	Bush	Moyeu	Büchse	Buje
33	2774786 000	3		Rondella bombata	Kasher	Rondelle	Scheibe	Arandela
34	1146360 000	2		Bullone flangiato M5x16	Head Flanged bolt M5x16	Boulon Bridé M5x16	Bundbolzen M5x16	Bulón con Brida M5x16
35	1312610 000	1		Dado	Nut	Ecrou	Mutter	Tuerca
36	1349191 000	1		Distanziale	Spacer	Entretoise	Distanzstück	Distanciadador
37	1354820 000	1		Distanziale 6,5x9,0x13,5	Spacer 6,5x9,0x13,5	Entretoise 6,5x9,0x13,5	Distanzstück 6,5x9,0x13,5	Distanciadador 6,5x9,0x13,5
38	1313020 000	1		Dado autobloccante M6	Self locking nut M6	Ecrou de sécurité M6	Mutter, selbstsichernd M6	Tuerca de seguridad M6
39	1348868 000	1		Distanziale tassello guidacatena	Sliding block spacer	Entretoise cheville guide de chaine	Abstandstück Schwingschleifklotz	Separador protector cadena/basculante
40	1105535 000	1		Bullone 6.50 rs ch 8	Bolt 6.50 rs ch 8	Boulon 6.50 rs ch 8	Bolzen 6.50 rs ch 8	Tornillo 6.50 rs ch 8
41	1149070 000	1		Bullone 6x20 ch rs	Bolt 6x20 ch rs	Boulon 6x20 ch rs	Bolzen 6x20 ch rs	Tornillo 6x20 ch rs
42	1629620 000	2		Gommino fissaggio	Fastening rubber	Caoutchouc de fix.	Gummi Befestigung	Goma fijación
43	1146401 000	2		Bullone M5x20	Bolt M5x20	Boulon M5x20	Bolzen M5x20	Tornillo M5x20
44	2910596 136	4		Tappo forcellone D30	Big fork plug D30	Bouchon fourche D30	Radschwinge verschluß D30	Tapón horquilla D30
45	1514605 000	2		Passatubo	Grommet	Passe-tube	Rohrdurchgang	Pasa-tubo
46	2011505 000	1		Kit guarnizioni	Packings kit	Jeu joints	Dichtungensatz	Grupo juntas
47	1354820 000	1		Distanziale 6,5x9,0x13,5	Spacer 6,5x9,0x13,5	Entretoise 6,5x9,0x13,5	Distanzstück 6,5x9,0x13,5	Distanciadador 6,5x9,0x13,5
48	1317121 000	2		Dado speciale M8	Special nut M8	Ecrou spéciale M8	Spezialmutter M8	Tuerca especial M8
49	1155909 000	2		Bullone M8x55	Bolt M8x55	Boulon M8x55	Bolzen M8x55	Tornillo M8x55
50	1162050 000	2		Bullone fiss. ammortizzatore M10x45	Damper sec. bolt M10x45	Boulon fix. amortisseur M10x45	Befestigungsbolzen M10x45	Tornillo fij amortiguador M10x45
51	1321050 000	1		Dado flangiato M10X1,25	Flanged nut M10X1,25	Ecrou bordé M10X1,25	Flanschmutter M10X1,25	Tuerca embreadada M10X1,25
52	1386078 800	1		Kit distanziali ammortizzatore	Damper spacer kit	Jeu entretoises amortisseur	Kit Stoßdämpfer Distanz	Juego distanciadador amortiguador
53	1620821 000	1		Ghiera fissaggio ammortizz.	Shock absorber fixing ring nut	Bague fixation amortisseur	Befestigungsring stossdämpfer	Junta fijadora amortiguador
54	1620820 000	1		Ghiera registro ammortizz.	Shock absorber adjusting ring nut	Bague réglage amortisseur	Regulierungsring stossdämpfer	Junta regularización amortig.
55	020331410 000	1		Tampone	Buffer	Silentbloc	Puffer	Silent-block
56	1539110 000	1		Fondello	Cup	Godet	Deckel	Cazoleta
57	2011504 000	1		Kit gruppo guarniz. Ammort.	Shock absorber gasket set	Joints amortisseur	Dichtungensatz stossdämpfer	Juego juntas amortiguador
58	020331420 000	1		Gruppo forchetta ammortizz.	Shock absorber inf. Connection	Fxation inferieur amortisseur	Untere befestigung stossdämpfer	Fijador inferior amortiguador
59	1146251 000	4		Bullone flangiato M5x12	Head Flanged bolt M5x12	Boulon Bridé M5x12	Bundbolzen M5x12	Bulón con Brida M5x12

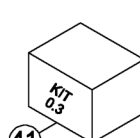
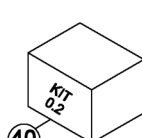
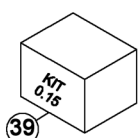
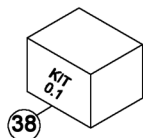
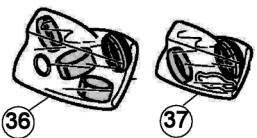
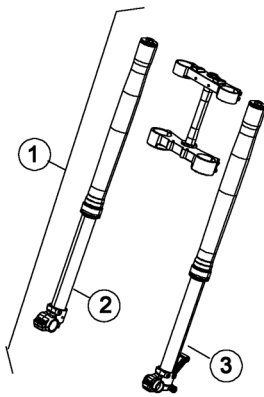
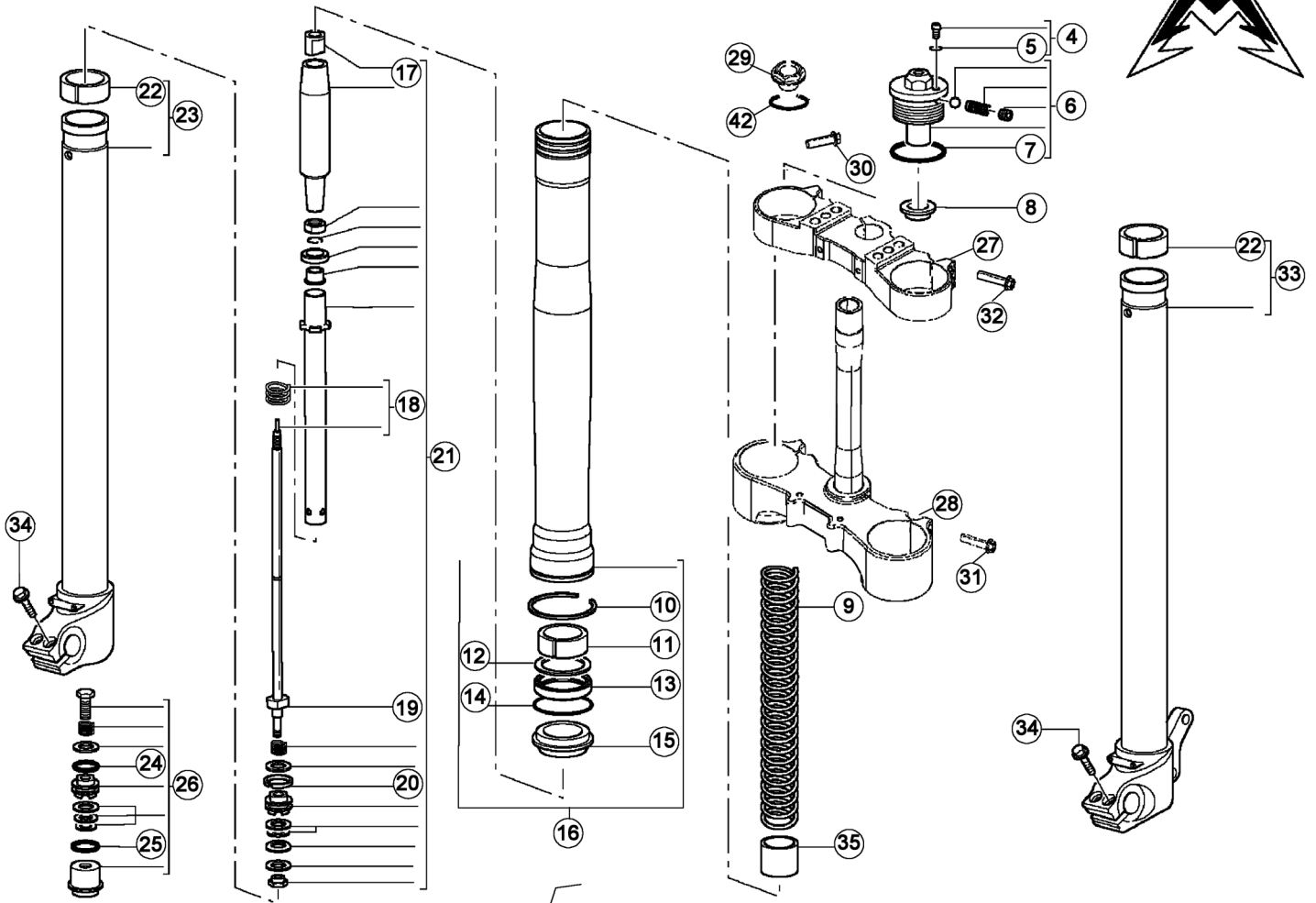
# Tav.20





- Olio forcella
- Fork oil
- Gabelöl
- Huile de fourche
- Aceite de horquilla

BETA consiglia:  
 BETA raccomanda:  
 BETA empfiehlt:  
 BETA recommande:  
 BETA recomienda:

**Marzocchi SAE 7,5**

# Tav.20

Pos Loc Pos Ps Pos	Numero Number Numéro Número Nummer	Q.tà Q.ty Q.té M.ge C.ad	Nota Note Note Nota Anm.	Descrizione	Description	Désignation	Beschreibung	Descripción
1	020341008 000	1		Forcella D.50	Fork D.50	Fourche D.50	Gabel D.50	Horquilla D.50
2	020341308 059	1		Gamba forcella dx completa	Complete right fork leg	Jante droit compl. Fourche	Gabelbein re	Brazo horquilla derecho compl.
3	020341108 059	1		Gamba forcella sx completa	Complete left fork leg	Jante gauche compl. Fourche	Gabelbein li.	Brazo horquilla izquierdo compl.
4	020340058 000	2		Vite TCIC M4X6 + OR2015	Screw TCIC M4X6 + OR2015	Vis TCIC M4X6 + OR2015	Schraube TCIC M4X6 + OR2015	Tornillo TCIC M4X6 + OR2015
5	020340060 000	2		Or D3x69 S1.78	o-ring, plug screw D3x69 S1.78	Or D3x69 S1.78	O-Ring D3x69 S1.78	Or D3x69 S1.78
6	020341078 000	2		Gruppo tappo	Plug assy	Groupe bouchon	Verschlussgruppe Kpl	Grupo tapón
7	020341080 000	2		Or 146	O-ring, 146	Or 146	O-Ring 146	Or 146
8	020341150 000	2		Anello porta molla	Spring holder ring	Anneau porte-ressort	Ring Federhalter	Anello porta muelle
9	020341160 000	2		Molla	Spring	Ressort	Feder	Muelle
10	1041060 000	1		Anello	Ring	Circlips	Ring	Anillo
11	1131313 000	2		Boccola superiore	Upper bush	Douille supérieure	Obere Buchse	Casquillo superior
12	2814110 000	2		Scodellino	Stop washer	Rondelle d'ar	Federaufnahme	Platillo
13	1041466 000	2		Anello di tenuta	Oil seal	Joint spie	Dichtring	Retén de aceite
14	1041053 000	2		Anello Dx63	Ring Dx63	Circlips Dx63	Ring Dx63	Anillo Dx63
15	020341090 000	2		Raschiapolvere	Dust scraper	Graffe poussiere	Staubabstreifer	Esc. polvo
16	1618667 000	2		Portastelo completo	Slider assembly	Porte-fourreau complet	Gleitrohr komplett	Botella completa
17	1329531 000	2		Controdado M12X1x25	Lock-nut M12X1x25	Contre-écrou M12X1x25	Kontermutter M12X1x25	Contratuercas M12X1x25
18	020341230 000	2		Asta interna	Internal rod	Barre	Stange	Varilla
19	020340210 000	2		Ass. asta	Rod assy	Barre compl.	Stange Kpl	Grupo varilla
20	020341220 000	2		Segmento	Compression ring	Segment	Kompressions-Kolbenring	Aro de compresión
21	020341208 000	2		Gruppo asta completa	Rod assembly	Groupe tige complète	Pumpenelementsstab komplett	Varilla completa
22	1131312 000	2		Boccola inferiore	Lower bush	Douille inférieure	Untere Buchse	Casquillo inferior
23	020341308 000	1		Tubo dx completo forcella	RH compl. Fork tube	Tube compl. Droit fourche	Gabelstandrohr rechts	Tubo derecho compl. Horquilla
24	020340180 000	2		Or 23,5X1,0	o-ring, plug screw 23,5X1,0	Or 23,5X1,0	O-Ring 23,5X1,0	Or 23,5X1,0
25	020340190 000	2		Or D25x1 S1.78	o-ring, plug screw D25x1 S1.78	Or D25x1 S1.78	O-Ring D25x1 S1.78	Or D25x1 S1.78
26	020341178 000	2		Ass. valvola di fondo	Valve	Soupape	Ventil	Válvula
27	020341020 004	1		Testa di sterzo	Steering head	Tête de direction	Gabelkopf	Tija superior
28	020341018 004	1		Crociera con canotto	Lowe yoke	Croisiere a/tube fourche	Untere Gabelbrücke	Pletina con tubo
29	020340040 004	1		Dado M20X1,5	Nut M20X1,5	Ecrou M20X1,5	Mutter M20X1,5	Tuerca M20X1,5
30	1155440 000	1		Vite speciale M8X30	Special screw M8X30	Vis spéciale M8X30	Spezialschraube M8X30	Tornillo especial M8X30
31	1155510 000	2		Vite speciale M8X40	Special screw M8X40	Vis spéciale M8X40	Spezialschraube M8X40	Tornillo especial M8X40
32	1155510 000	2		Vite speciale M8X40	Special screw M8X40	Vis spéciale M8X40	Spezialschraube M8X40	Tornillo especial M8X40
33	020341108 000	1		Tubo sx completo forcella	LH compl. Fork tube	Tube compl. Gauche fourche	Gabelstandrohr links	Tubo izquierdo compl. Horquilla
34	3159004 000	4		Vite TEF M 6X25	Screw TEF M 6X25	Vis TEF M 6X25	Schraube TEF M 6X25	Tornillo TEF M 6X25
35	020341240 000	2		Tubo precarico molla 46X3.5X43	Fork spring tube 46X3.5X43	Tube ressort forche 46X3.5X43	Federschlauch Gabel 46X3.5X43	Tubo muelle horquilla 46X3.5X43
36	020341278 000	1		Kit boccole	Bush kit	Kit douille	Buchsekit	Kit manguito
37	020341268 000	1		Gr. minuterie	Set small items	Jeu menuiseries	Gr. rev. motor	J. menudencias
38	020340508 000	1	0,1	Kit lamelle	Plate kit	Kit lamelle	Plättchenkit	Kit Laminilla
39	020340518 000	1	0,15	Kit lamelle	Plate kit	Kit lamelle	Plättchenkit	Kit Laminilla
40	020340528 000	1	0,2	Kit lamelle	Plate kit	Kit lamelle	Plättchenkit	Kit Laminilla
41	020340538 000	1	0,3	Kit lamelle	Plate kit	Kit lamelle	Plättchenkit	Kit Laminilla
42	1066420 000	1		Or 20,22-3,53 NBR	o-ring 20,22-3,53 NBR	Or 20,22-3,53 NBR	O-Ring 20,22-3,53 NBR	Or 20,22-3,53 NBR

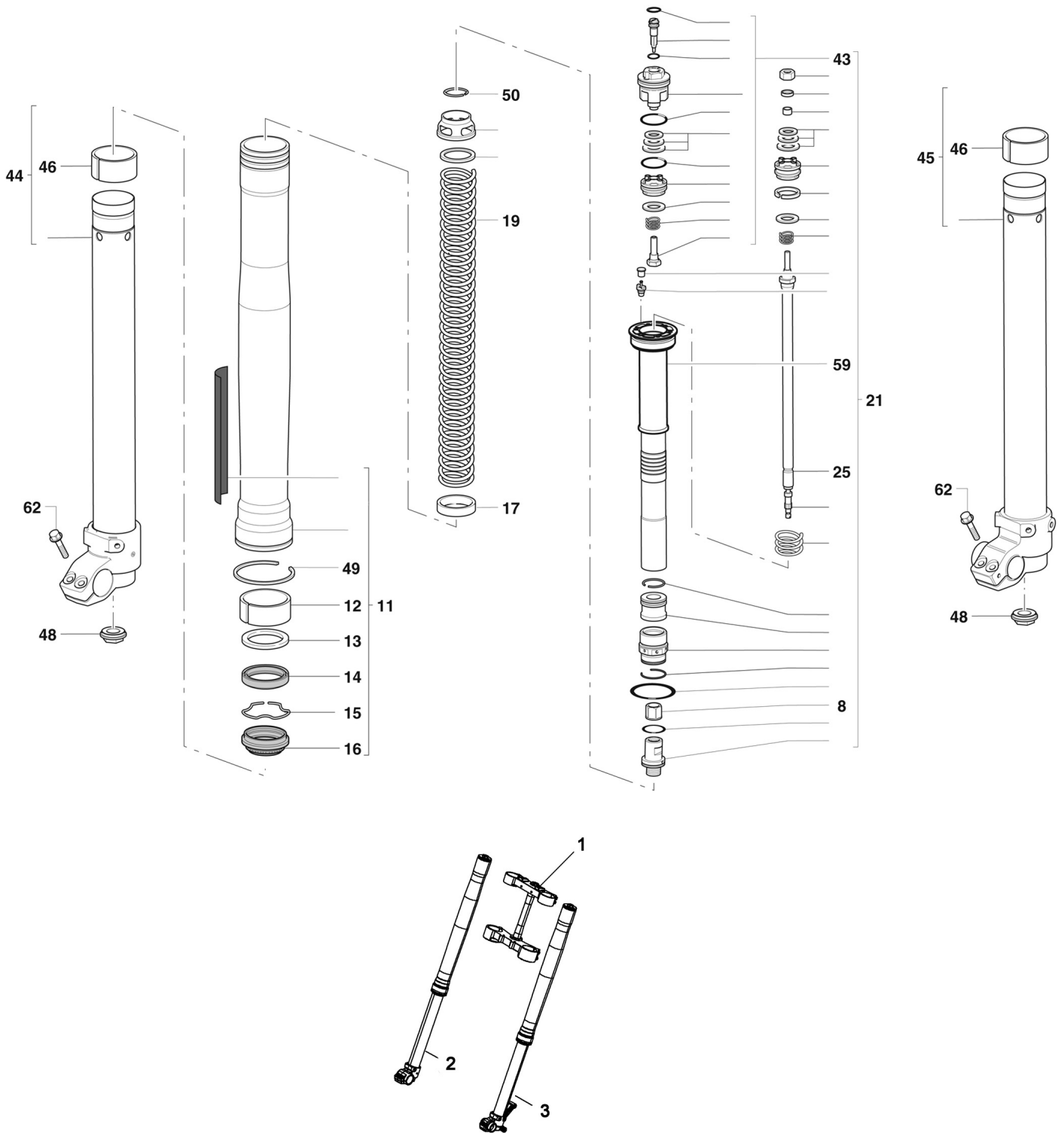

# Tav.20A

Pos Loc Pos Ps Pos	Numero Number Numéro Número Nummer	Q.tà Q.ty Q.té M.ge C.ad	Nota Note Note Nota Anm.	Descrizione	Description	Désignation	Beschreibung	Descrìcion
1	020340618 000	1		Kit piastre forcella	Steering plates kit, fork	Jeu tête de fourche	Gabelbrücken	Kit pletinas horquilla
2	020342308 059	1		Gamba forcella dx completa	Complete right fork leg	Jante droit compl. Fourche	Gabelbein re	Brazo horquilla derecho compl.
3	020342108 059	1		Gamba forcella sx completa	Complete left fork leg	Jante gauche compl. Fourche	Gabelbein li.	Brazo horquilla izquierdo compl.
8	1329531 000	1		Controdado M12X1x25	Lock-nut M12X1x25	Contre-écrou M12X1x25	Kontermutter M12X1x25	Contratuercia M12X1x25
11	1618667 000	2		Gruppo asta completa	Rod assembly	Groupe tige complète	Pumpenelementsstab komplett	Varilla completa
12	1131313 000	2		Boccola superiore D50 H15	Upper bush D50 H15	Douille supérieure D50 H15	Obere Buchse D50 H15	Casquillo superior D50 H15
13	2814110 000	2		Scodellino D50 65x51x3	Stop washer D50 65x51x3	Rondelle d'ar D50 65x51x3	Federaufnahme D50 65x51x3	Platillo D50 65x51x3
14	1041466 000	2		Anello di tenuta	Oil seal	Joint spie	Dichtring	Retén de aceite
15	1041053 000	2		Anello Dx63	Ring Dx63	Circlips Dx63	Ring Dx63	Anillo Dx63
16	1041481 000	2		Raschiapolvere	Dust scraper	Graffe poussiere	Staubabstreifer	Esc. polvo
17	2940472 000	2		Tubo precarico molla	Fork spring tube	Tube ressort forche	Federschlauch Gabel	Tubo muelle horquilla
19	2252711 000	2		Molla K4,8	Spring K4,8	Ressort K4,8	Feder K4,8	Muelle K4,8
21	1232984 000	2		Gruppo asta completa	Rod assembly	Groupe tige complète	Pumpenelementsstab komplett	Varilla completa
25	1232986 000	2		Ass. asta	Rod assy	Barre compl.	Stange Kpl	Grupo varilla
43	1643200 000	2		Gruppo valvola	Valve unit	Ensemble clapet	Ventilaggregat	Grupo válvula
44	020342318 000	1		Tubo dx completo forcella	RH compl. Fork tube	Tube compl. Droit fourche	Gabelstandrohr rechts	Tubo derecho compl. Horquilla
45	020342118 000	1		Tubo sx completo forcella	LH compl. Fork tube	Tube compl. Gauche fourche	Gabelstandrohr links	Tubo izquierdo compl. Horquilla
46	1131312 000	2		Boccola inferiore	Lower bush	Douille inférieure	Untere Buchse	Casquillo inferior
48	1329532 000	2		Dado di fondo	Bottom nut	Ecrou inf.	Bodenmutter	Tuerca del fondo
49	1041060 000	2		Anello Dx62	Ring Dx62	Circlips Dx62	Ring Dx62	Anillo Dx62
50	1041479 000	2		Anello Dx30,5	Ring Dx30,5	Circlips Dx30,5	Ring Dx30,5	Anillo Dx30,5
59	1232987 000	2		Cartuccia forcella (custodia)	Fork spares	Cartouche fourche	Gabeldämpfer	Cartucho horquilla
62	3130573 000	4		Vite TEF M 6X25	Screw TEF M 6X25	Vis TEF M 6X25	Schraube TEF M 6X25	Tornillo TEF M 6X25

# Tav.21

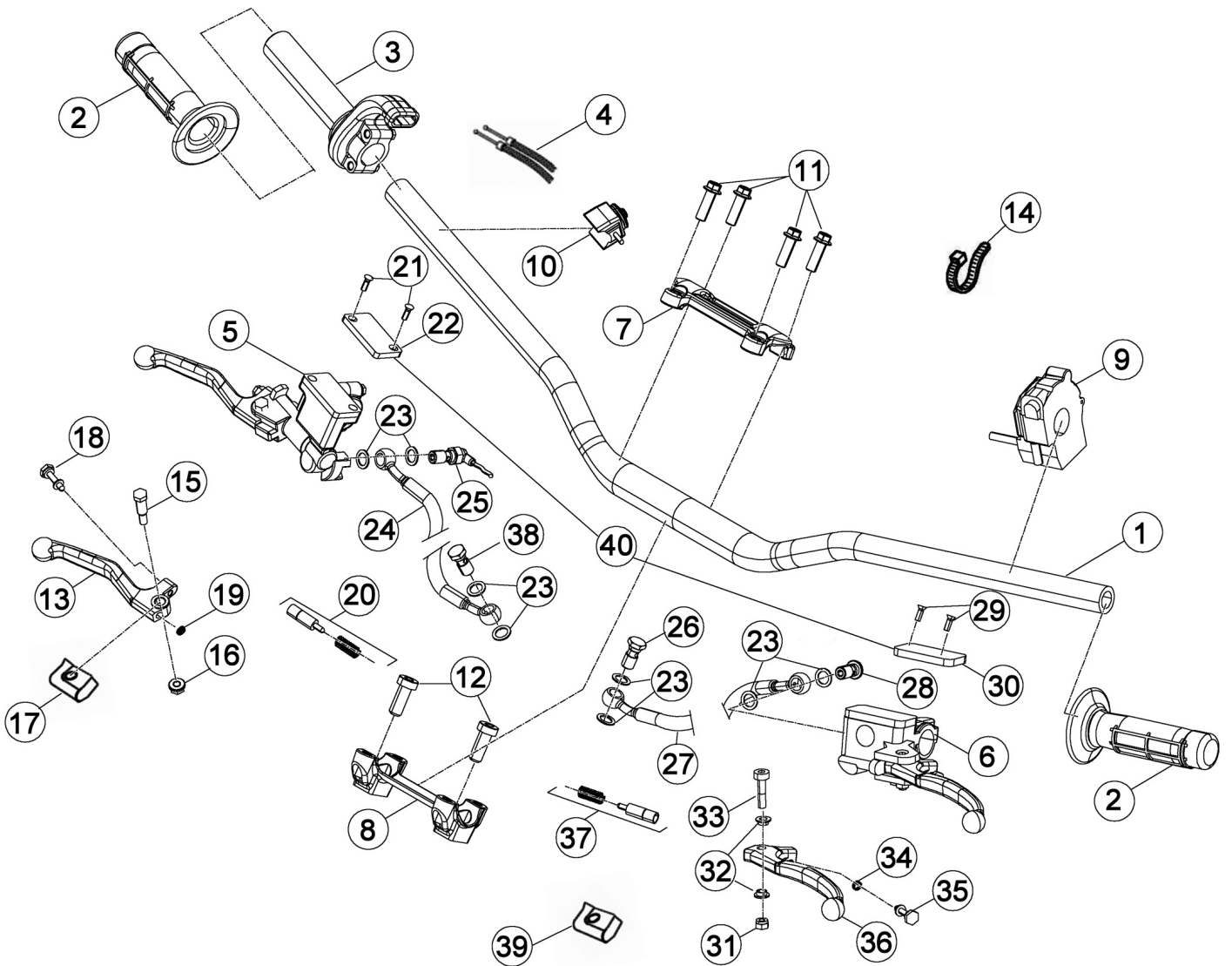
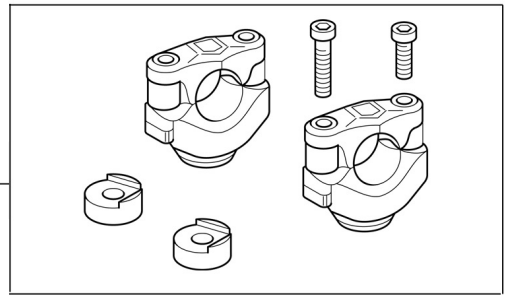
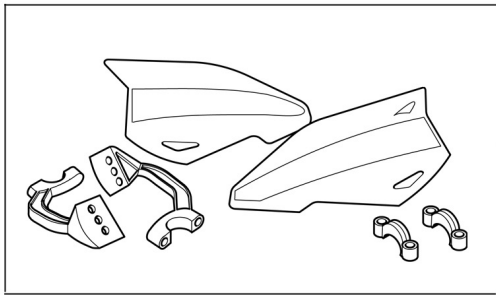

# Tav.21

Pos Loc Pos Ps Pos	Numero Number Numéro Número Nummer	Q.tà Q.ty Q.té M.ge C.ad	Nota Note Note Nota Anm.	Descrizione	Description	Désignation	Beschreibung	Descrìcion
1	2220391 000	1		Manubrio	Handlebars	Guidon	Lenker	Manillar
2	2218537 000	1		Coppia manopole	Grips (couple)	Poignées (couple)	Handgriffpaar	Manecilla (juego)
3	1255097 000	1		Comando gas	Throttle control	Comm. gaz	Gasdrehgriff	Mando gas
4	020350100 000	1		Trasmissione gas	Throttle transmiss.	Transmission gaz	Gaszug	Transmisión gas
5	2102057 000	1		Leva freno ant.	Fr. br. lever	Lev. fr. AV.	Vorderradbremshebel	Pal. fr. del.
6	2102433 000	1		Leva comando frizione	Clutch control lever	Levier de commande embrayage	Kupplungshebel	Palanca mando embrague
7	1208253 000	1		Cavallotto superiore	Upper u bolt	Etrier sup.	Obere Brücke	Brida sup.
8	1208263 000	1		Cavallotto inferiore	Lower u bolt	Etrier inférieure	Untere Brücke	Brida inferior
9	1306506 000	1		Commutatore luci	Lights switch	Commutateur feux	Lichtschalter	Conmutador luces
9	1306508 000	1	FACTORY	Commutatore luci	Lights switch	Commutateur feux	Lichtschalter	Conmutador luces
10	1884981 000	1		Interruttore avviamento	Starter switch	Commutateur demarrage	Anlasschalter	Interruptor de arranque
11	3164070 000	4		Vite flangiata 8x30	Flanged screw 8x30	Vis à brides 8x30	Flanschschraube 8x30	Tornillo rebordeado 8x30
12	3165626 000	2		Vite a brugola M10 25	Allen screw M10 25	Vis à 6 pans M10 25	Sechskantschraube M10 25	Tornillo a llave allen M10 25
13	2127104 000	1		Leva freno	Brake lever	Levier du frein	Bremshebel	Palanca de freno
14	1514264 000	1		Fascetta	Clamp	Collier	Schelle	Abrazadera
15	3196832 000	1		Perno leva freno	Brake lever pin	Goujon levier frein	Bremshebelstift	Perno leva freno
16	1330911 000	1		Dado	Nut	Ecrou	Mutter	Tuerca
17	1633841 000	1		Coprileva	Lever cover	Couvre levier	Hebeldeckel	Cubre-palanca
18	3188604 000	1		Vite regol. leva	Adjusting screw	Vis réglage	Einstellschrauben	Tornillo reg.
19	2238704 000	1		Molla registro leva freno ant.	Front brake lever adjust spring	Ressort enregistrement levier	Regelfeder vorderradbremse	Muelle regul. bomba freno
20	2008258 000	1		Pistoncino completo pompa	Piston assy, pump	Piston compl. pompe	Kolben klpt. Pumpe	Piston completo bomba
21	3123402 000	2		Vite fiss. coperchio	Cover sec. screw	Vis de fix. couvercle	Schraube	Tornillo
22	2008259 000	1		Coperchio serbatoio olio	Oil filler cover	Couvercle réservoir huile	Ölverschlußdeckel	Tapa depósito aceite
23	1650510 000	8		Guarnizione 10x15x1 in rame	Gasket 10x15x1 copper	Joint 10x15x1 cuivre	Dichtung 10x15x1 Kupfer	Junta 10.15.1 (cobre)
24	2909108 000	1		Tubo Freno Ant.	Front brake tube	Tuyau du frein AV.	Vordere Bremsleitung	Tubo freno delantero
25	1889621 000	1		Interruttore stop	Stop switch	Interrupteur stop	Stopschalter	Interruptor stop
26	1165040 000	1		Bullone forato 10x1 x tubo freno	Special bolt	Boulon 10x1 x tube frein	Hohlschraube F.Bremse	Tornillo esp. talad.10.1
27	020350010 000	1		Tubo frizione	Clutch tube	Canalisation embrague	Kupplungsrohr	Tubo embrague
28	1165035 000	1		Bullone forato	Pierced bolt	Boulon avec trou	Bolzen	Tornillo
29	3123401 052	2		Vite fiss. coperchio	Cover sec. screw	Vis de fix. couvercle	Schraube	Tornillo
30	2005078 000	1		Serbatoio olio	Oil tank	Reserv.huile	Öltank	Tanque aceite
31	1330912 000	1		Dado	Nut	Ecrou	Mutter	Tuerca
32	1126466 000	2		Boccola	Bush	Moyeu	Büchse	Buje
33	3196819 000	1		Vite fiss. leva	Fixing lever screw	Vis fix. levier	Schraube hebel	Tornillo fij. palanca
34	2238702 000	1		Molla regolazione frizione	Clutch spring	Ressort réglage embrayage	Stellfeder	Muelle regulac. embrague
35	3188602 000	1		Vite regol. frizione	Adjusting screw	Vis réglage	Einstellschrauben	Tornillo reg.
36	2127085 000	1		Leva frizione	Clutch lever	Levier d'embrayage	Kupplungshebel	Palanca embrague
37	2005084 000	1		Kit pistoncino pompa	Piston kit master cyl.	Kit piston. maître cyl.	Kolbensatz hauptbremszylinder	Kit pistón bomba
38	1165053 000	1		Bullone forato 10x1,25	Pierced bolt 10x1,25	Boulon avec trou 10x1,25	Bolzen 10x1,25	Tornillo 10x1,25
39	1692710 000	1		Gomma protezione leva frizione	Clutch lever protection grommet	Caoutchouc protection levier emb.	Gummi Hebelschutz	Goma protección palanca embr.
40	020450398 000	1	FACTORY	Kit coperchi pompa	Pump cover kit	Jeu couvercles pompe	Bausatz pumpendeckel	Kit tapas bomba
41	020450158 051	1	FACTORY	Kit paramani "VERTIGO"	Hand guards kit "VERTIGO"	Kit pare-mains "VERTIGO"	Kit Handschutz "VERTIGO"	Kit para manos "VERTIGO"
42	020450138 000	1	FACTORY	Supporti manubrio con PHDS	Handlebar mount with PHDS	Support de guidon avec PHDS	Lenkeralterungen mit PHDS	Soporte manillar con PHDS

# Tav.22

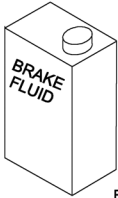

- Olio freni
- Brake fluid
- Bremsflüssigkeit
- Liquide de frein
- El líquido de frenos

BETA consiglia:  
 BETA recommends:  
 BETA empfohlen:  
 BETA recommande:  
 BETA recomienda:

**BARDAHL BRAKE FLUID DOT 4**  
**BARDAHL BRAKE FLUID DOT 5.1**

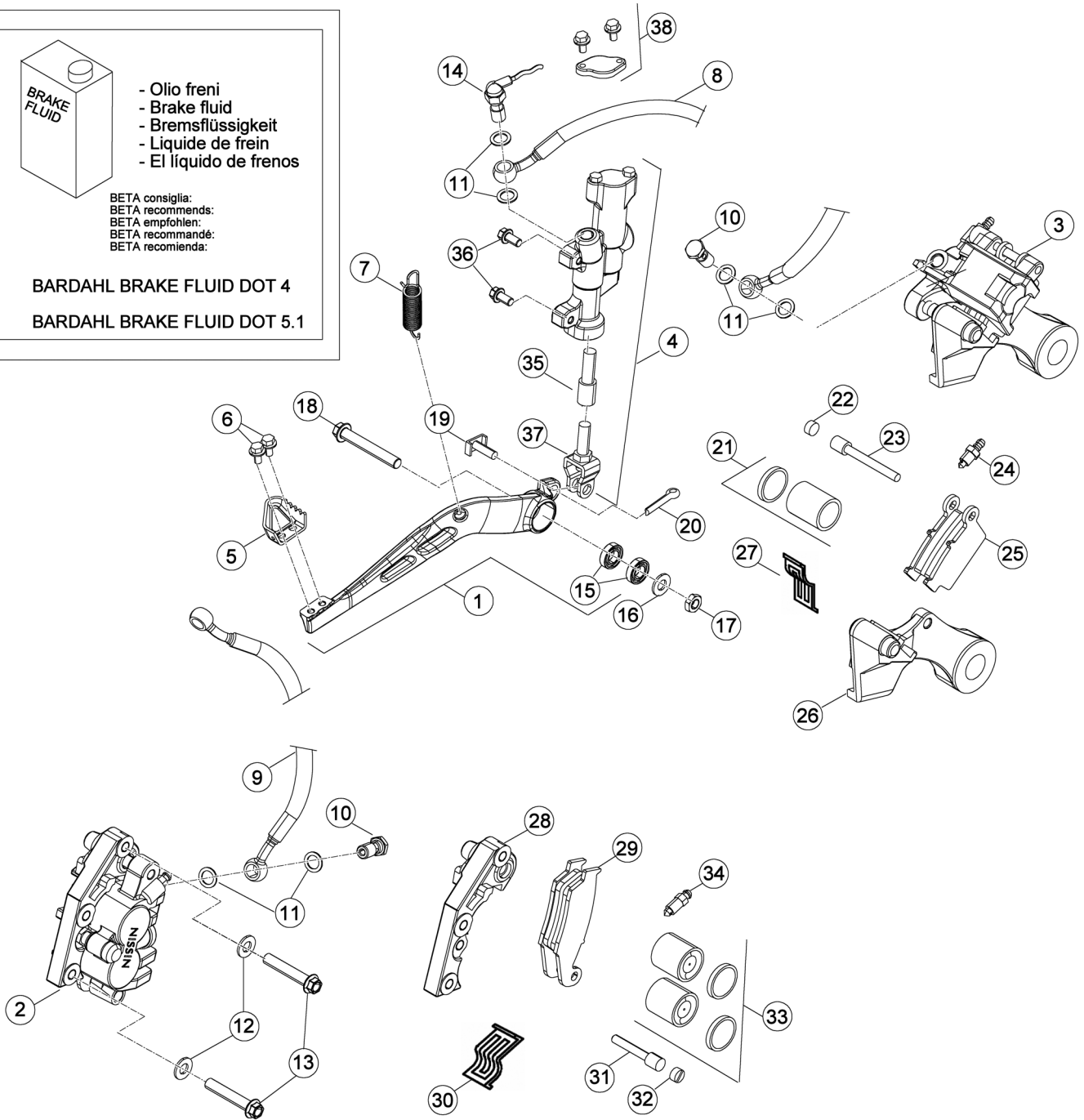

**Beta**  
 the play bike



# Tav.22

Pos Loc Pos Ps Pos	Numero Number Numéro Número Nummer	Q.tà Q.ty Q.té M.ge C.ad	Nota Note Note Nota Anm.	Descrizione	Description	Désignation	Beschreibung	Descrìcion
1	020360018 000	1		Pedale freno	Brake pedal	Pédale frein	Fussbremspedal	Pedal freno
2	2503056 000	1		Pinza freno anteriore	Front disk brake caliper	Etrier de frein AV.	Bremszange-Scheibe	Pinza freno del.
3	2503066 000	1		Pinza freno posteriore	Rear disk brake caliper	Etrier de frein AR.	Bremszange	Pinza del freno tras.
4	2591178 000	1		Pompa freno posteriore	Rear brake cylinder	Maître cylindre frein ar.	Hauptbremszylinder Hinterradbremse	Bomba freno trasero
5	2290053 000	1		Mozzetto	Hub	Moyeu	Nabe	Cubo
6	1146251 000	2		Bullone flangiato M5x12	Head Flanged bolt M5x12	Boulon Bridé M5x12	Bundbolzen M5x12	Bulón con Brida M5x12
7	2248813 000	1		Molla pedale freno	Brake pedal spring	Ressort Pédale Frein	Feder Fussbremspedal	Muelle pedal de freno
8	2909428 000	1		Tube Freno Posteriore	Rear brake tube	Tuyau du frein AR.	Hintere Bremsleitung	Tube freno trasero
9	2909108 000	1		Tube Freno Ant.	Front brake tube	Tuyau du frein AV.	Vordere Bremsleitung	Tube freno delantero
10	1165053 000	2		Bullone forato 10x1,25	Pierced bolt 10x1,25	Boulon avec trou 10x1,25	Bolzen 10x1,25	Tornillo 10x1,25
11	1650510 000	6		Guarnizione 10x15x1 in rame	Gasket 10x15x1 copper	Joint 10x15x1 cuivre	Dichtung 10x15x1 Kupfer	Junta 10.15.1 (cobre)
12	2749500 000	2		Rondella 8x18	Washer 8x18	Rondelle 8x18	U.Scheibe 8x18	Arandela 8x18
13	1155510 000	2		Bullone M8x40 ch10 rs	Bolt M8x40 ch10 rs	Boulon M8x40 ch10 rs	Bolzen M8x40 ch10 rs	Tornillo M8x40 ch10 rs
14	1889621 000	1		Interruttore stop	Stop switch	Interrupteur stop	Stopschalter	Interruptor stop
15	1293388 000	2		Cuscinetto 8x22x7	Bearing 8x22x7	Roulement 8x22x7	Lager 8x22x7	Cojinete 8x22x7
16	2749500 000	1		Rondella 8x18	Washer 8x18	Rondelle 8x18	U.Scheibe 8x18	Arandela 8x18
17	1317020 000	1		Dado autoblocc. Basso M8	Nut M8	Ecrou M8	Mutter M8	Tuerca M8
18	3163985 000	1		Vite M8x50	Screw M8x50	Vis M8x50	Schraube M8x50	Tornillo M8x50
19	2541830 000	1		Forcellino	Clip	Ressort	Fixiergabel	Horquilla
20	1281995 000	1		Copiglia 2x15	Split pin 2x15	Goupille 2x15	Splint 2x15	Grupilla 2x15
21	2002717 000	1		Kit pistoncini e guarniz. Pinza	Piston e oil seal for pliers	Jeu petit pistons et joint pincés	Reparatursatz Bremszange	Juego piston y guarnicion pinza
22	3196821 000	1		Grano	Dowel	Goujon	Stift	Clavija
23	2541860 000	1		Perno ancoraggio pastiglia	Pin hanger	Pivot ancrage	Halter brehsbelage	Varilla esp. Pastillas pinzas
24	2891002 000	1		Sfiato	Breather	Reniflard	Entlüfter	Respiradero
25	2525362 000	1		Pastiglie freno post.	Rear brake pads	Pastill. de freins AR.	Hinterbremsbelag	Pastillas frenos tras.
26	020360110 000	1		Staffa supporto pinza	Caliper support bracket	Bride support étrier	Bremssattelbefestigung	Brida soporte pinza
27	2232208 000	1		Molla ferma pastiglie pinza	Brake pads spring for pliers	Ressort arret plaquettes	Haltefeder	Muelle pastillas pinza
28	020360120 000	1		Staffa supporto pinza	Caliper support bracket	Bride support étrier	Bremssattelbefestigung	Brida soporte pinza
29	2525361 000	1		Pastiglie freno ant.	Front brake pads	Pastill. de freins AV.	Vorderbremsbelag	Pastillas frenos del.
30	2232207 000	1		Molla ferma pastiglie pinza	Brake pads spring for pliers	Ressort arret plaquettes	Haltefeder	Muelle pastillas pinza
31	2541859 000	1		Perno ancoraggio pastiglia	Pin hanger	Pivot ancrage	Halter brehsbelage	Varilla esp. Pastillas pinzas
32	3196821 000	1		Grano	Dowel	Goujon	Stift	Clavija
33	2002716 000	1		Kit pistoncini e guarniz. Pinza	Piston e oil seal for pliers	Jeu petit pistons et joint pincés	Reparatursatz Bremszange	Juego piston y guarnicion pinza
34	2891001 000	1		Sfiato	Breather	Reniflard	Entlüfter	Respiradero
35	2008276 000	1		Kit pistoncino pompa post.	Piston kit rear master cyl.	Kit piston. maître cyl. AR.	Kolbensatz hinterhauptbremszylinder	Kit pistón bomba tras.
36	3130750 000	2		Vite M6x16	Screw M6x16	Vis M6x16	Schraube M6x16	Tornillo M6x16
37	2008277 000	2		Kit leva	lever kit	Jeu levier	Hebelsatz	Juego palanca
38	2008275 000	1		Kit serbatoio pompa	Kit, pump tank	Kit reservoir pompe	Deckel pumpstake	Kit deposito bomba

# Tav.23

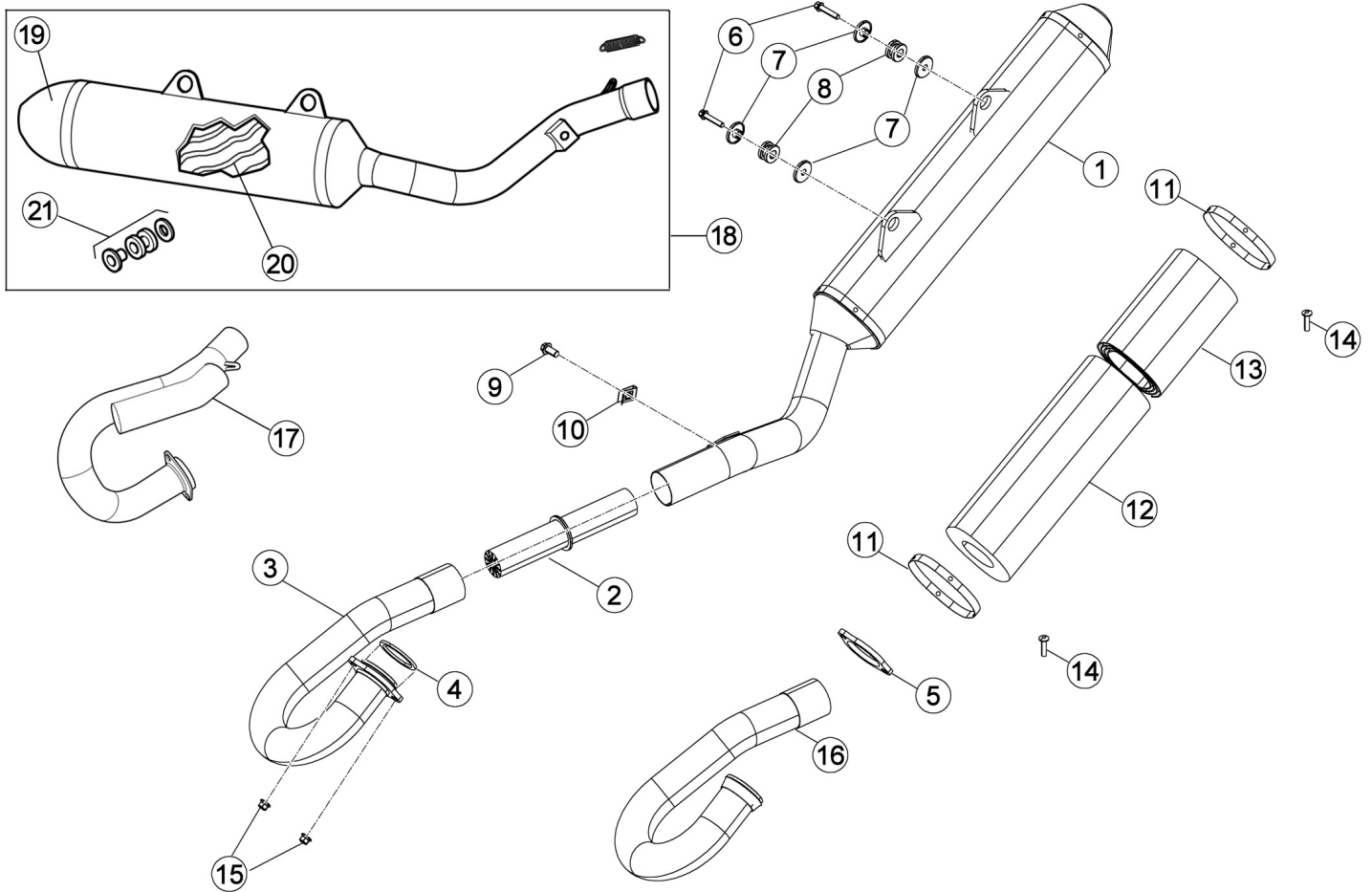

Pos Loc Ps Pos	Numero Number Numéro Número Nummer	Q.tà Q.ty Q.té M.ge C.ad	Nota Note Note Nota Anm.	Descrizione	Description	Désignation	Beschreibung	Descripción
1	020370208 000	1		Silenziatore completo	Silencer complete	Silencieux complet	Endschalldämpfer	Silenciador completo
2	020370080 000	1		Catalizzatore	Catalyst	Catalyseur	Katalysator	Catalizador
3	020371018 000	1	350	Collettore di scarico	Exhaust manifold	Collecteur d'échapp.	Abgaskrümmner	Colector de escape
3	020370018 000	1	400-450 520	Collettore di scarico	Exhaust manifold	Collecteur d'échapp.	Abgaskrümmner	Colector de escape
4	020370040 000	1		Guarnizione scarico	Exhaust manifold gasket	Joint coll. Ech.	Dichtung Abgaskrümmner	Junta colector de escape
5	020371030 000	1	350	Flangia marmitta	Silencer flange	Bride silencieux	Flansch Auspufftopf	Brida silenciador
5	020370030 000	1	400-450 520	Flangia marmitta	Silencer flange	Bride silencieux	Flansch Auspufftopf	Brida silenciador
6	1150300 000	2		Bullone 6x30 ch rs	Bolt 6x30 ch rs	Boulon 6x30 ch rs	Bolzen 6x30 ch rs	Tornillo 6x30 ch rs
7	1349187 000	4		Scodellino	Stop washer	Rondelle d'ar	Federaufnahme	Platillo
8	2891946 000	2		Silentbloc	Silentbloc	Silentbloc	Puffer	Silent-block
9	1147015 000	1		Bullone M6x12	Bolt M6x12	Boulon M6x12	Bolzen M6x12	Tornillo M6x12
10	2560311 000	1		Clip M6	Clip M6	Clip M6	Clip M6	Clip M6
11	020370230 000	2		Fascetta	Clamp	Collier	Schelle	Abrazadera
12	020370210 000	1		Preformato silenziatore	Inner component, silencer	Pre-format silencieux	Daemmaterial	Fibra cartucho silencioso
13	020370220 000	1		Elemento isolante	Insulation	Antibruiit	Daempfung	Amortiguacion
14	020370240 000	8		Rivetto	Rivet	Rivet	Niete	Remache
15	1317121 000	2		Dado speciale M8	Special nut M8	Ecrou spéciale M8	Spezialmutter M8	Tuerca especial M8
16	020371010 000	1	350	Tubo collettore	Collector pipe	Tube collect	Sammelrohr	Tubo colector
16	020370010 000	1	400-450 520	Tubo collettore	Collector pipe	Tube collect	Sammelrohr	Tubo colector
17	020372018 000	1	FACTORY	Collettore di scarico in titanio	Exhaust manifold, titanium	Collecteur d'échapp. en titanie	Abgaskrümmner in titan	Colector de escape en titanio
18	020372208 000	1	FACTORY	Silenziatore completo in titanio	Silencer complete, titanium	Silencieux complet en titanie	Endschalldämpfer in titan	Silenciador completo en titanio
19	020372268 000	1	FACTORY	Kit fondello CARBY	Kit silencer end cap CARBY	Jeu embout de silencieux CARBY	Kit Enddämpferendkappe CARBY	Cazoleta final silenciador CARBY
20	020372258 000	1	FACTORY	Kit materiale fonoassorbente	Kit of sound absorbing material	Jeu matériau insonore	Kit Schalldämpfendem	Material fonoabsorbente
21	020372278 000	1	FACTORY	Kit silentbloc-distanziale-vite	Kit silentbloc-spacer-screw	Jue silentbloc-entretoise-vis	Kit puffer-Distanzstück-Schraube	Kit Silentbloc-Distanciadador-Tornillo



**Beta**  
the play bike

# Tav.24

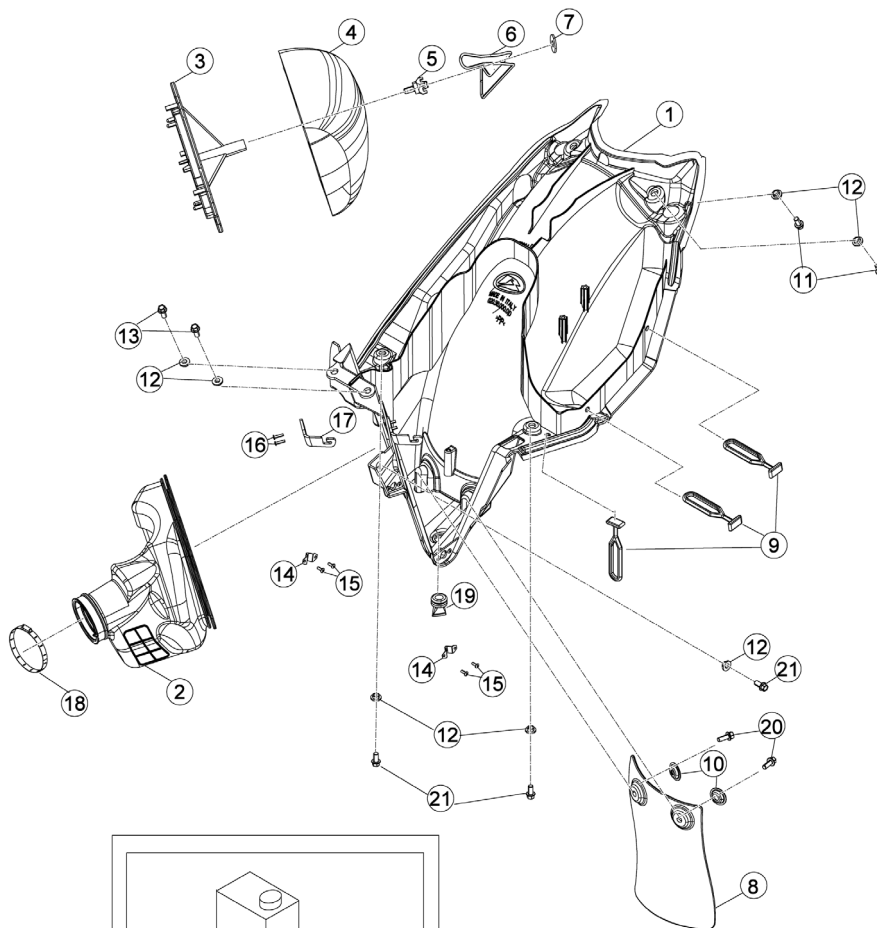

- Olio per filtri ad alta penetrazione  
 - High penetration filter's oil  
 - Hohe Durchdringung der Öl-Filter  
 - Huile à filtre à haute pénétration  
 - Aceite de filtro de alta penetración

Pos	Numero	Q.tà	Nota	Descrizione	Description	Désignation	Beschreibung	Descripcìon
Loc	Number	Q.ty	Note					
Pos	Numéro	Q.té	Note					
Ps	Número	M.ge	Nota					
Pos	Nummer	C.ad	Anm.					
1	020380008 059	1		Scatola filtro completa	Air cleaner box	Boîtier filtre à air	Luftfiltergehäuse	Caja filtro de aire
2	020380200 000	1		Manicotto scatola filtro	Filter box sleeve	Manchon boîte du filtre	Filtergehäusemuffe	Manguito caja filtro
3	1611215 000	1		Gabbia filtro aria	Filter cage	Grille filtre aire	Filter kafig	Jaula filtro aire
4	016380100 000	1		Filtro aria	Air filter	Filtere à air	Luftfilter	Filtro de aire
5	2557197 000	1		Perno richiamo ferma-filtro	Filter pin	Pivot filtre	Filtershalter	Pin Eje filtro
6	020380210 000	1		Molla fermafiltro	Filter spring	Ressort filtre	Filter Feder	Muelle filtro
7	2774800 000	1		Rondella autobloccante 9	Washer 9	Rondelle 9	Scheibe 9	Arandela 9
8	2524416 159	1		Paraspruzzi	Splash guard	Pare-boue	Koffluggellappen	Gomas aislantes
9	1634907 000	3		Gommino	Rubber buffer	Caoutchouc	Gummi	Goma
10	2774786 000	2		Rondella bombata	Kasher	Rondelle	Scheibe	Arandela
11	3130030 000	2		Vite autofilettante 6x15	Self tapping screw 6x15	Vis taraud 6x15	Schraube, Blech 6x15	Tornillo autorrosc. 6x15
12	1354820 000	7		Distanziale 6,5x9,0x13,5	Spacer 6,5x9,0x13,5	Entretoise 6,5x9,0x13,5	Distanzstück 6,5x9,0x13,5	Distanciador 6,5x9,0x13,5
13	1147015 000	2		Bullone M6x12	Bolt M6x12	Boulon M6x12	Bolzen M6x12	Tornillo M6x12
14	020380010 000	2		Ricettacolo	Receptacle	Réceptacle	Behälter	Receptaculo
15	2733801 000	4		Rivetto a strappo 3x8	Rivet 3x8	Rivet 3x8	Niet 3x8	Remache 3x8
16	2733802 000	2		Rivetto a strappo 3x12	Rivet 3x12	Rivet 3x12	Niet 3x12	Remache 3x12
17	020380020 000	1		Braccetto	Arm	Bras	Kleine Stütze	Brazo
18	1514272 000	1		Fascetta	Clamp	Collier	Schelle	Abrazadera
19	1634510 000	1		Tappo in gomma	Rubber cap	Bouchon en caoutchouc	Gummiverschluss	Tapón de goma
20	3130815 000	2		Vite autofilettante 6x20	Self tapping screw 6x20	Vis taraud 6x20	Schraube, Blech 6x20	Tornillo autorrosc. 6x20
21	1148025 000	3		Bullone 6x16 ch 8 rs	Bolt 6x16 ch 8 rs	Boulon 6x16 ch 8 rs	Bolzen 6x16 ch 8 rs	Tornillo 6x16 ch 8 rs



- Liquido di raffreddamento  
 - Cooling liquid  
 - Kühlfüssigkeit  
 - Liquide de refroidissement  
 - El liquido de refrigeración

BETA consiglia:  
 BETA recommends:  
 BETA empfiehlt:  
 BETA recommande:  
 BETA recomienda:

**BARDAHL ANTIFREEZE PLUS**

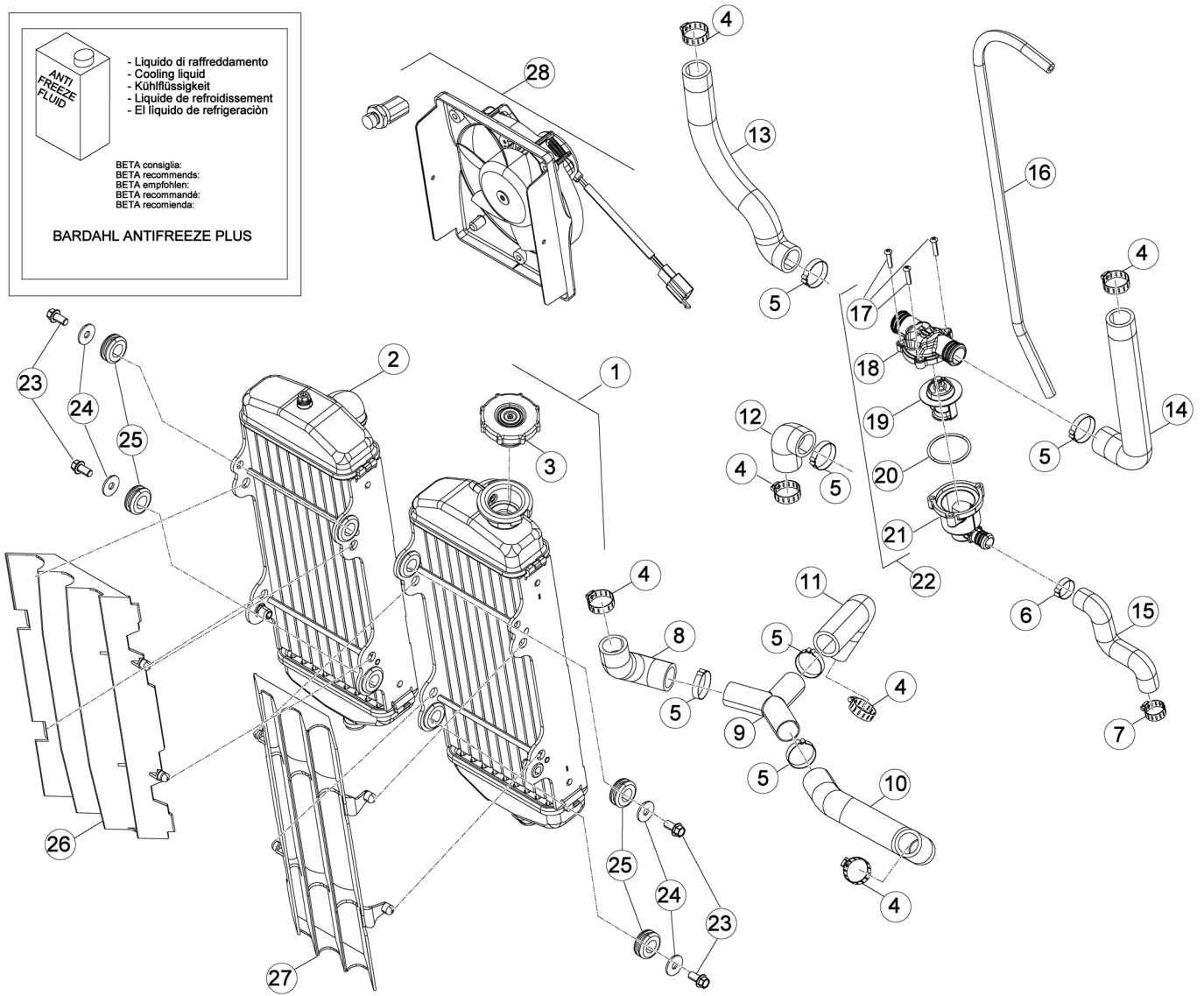

# Tav.25

Pos Loc Pos Ps Pos	Numero Number Numéro Número Nummer	Q.tà Q.ty Q.té M.ge C.ad	Nota Note Note Nota Anm.	Descrizione	Description	Désignation	Beschreibung	Descrìcion
1	020391100 000	1		Radiatore Sx	L.H. radiator	Radiateur G.	L., Kühler	Radiador iz.
2	020390000 000	1		Radiatore Dx	R.H. radiator	Radiateur D.	R., Kühler	Radiador der.
3	020391110 000	1		Tappo radiatore	Radiator plug	Bouchon radiateur	Kühlerdeckel	Tapa de radiador
4	1515240 000	6		Fascetta 19/28	Clamp 19/28	Collier 19/28	Schelle 19/28	Abrazadera 19/28
5	020390080 000	6		Fascetta 24	Clamp 24	Collier 24	Schelle 24	Abrazadera 24
6	020390090 000	1		Fascetta 17	Clamp 17	Collier 17	Schelle 17	Abrazadera 17
7	1515220 000	1		Fascetta 12/22	Clamp 12/22	Collier 12/22	Schelle 12/22	Abrazadera 12/22
8	020390060 000	1		Tubo inferiore radiatore dx	RH lower radiator tube	Tube radiateur droit inf.	Wasserschlauch Kühler unten/li.	Tubo radiador derecho inferior
9	020390200 000	1		Raccordo a Y	Y joint.p.	Raccord a Y	Y Stutzen	Racor a Y
10	020390050 000	1		Tubo inferiore radiatore sx	LH lower radiator tube	Tube radiateur gauche inf.	Wasserschlauch Kühler unten/re.	Tubo radiador izquierdo inferior
11	020390070 000	1		Tubo pompa acqua	Water pump pipe	Tube pompe eau	Leitung wasserpumpe	Tubo bomba agua
12	020390010 000	1		Tubo termostato	Thermostat hose	Tube interrupteur termique	Thermostatschlauch	Tubo termostato
13	020390040 000	1		Tubo radiatore dx-termostato	R.H. Radiator-Thermostat hose	Tuyau radiateur D.-interrupteur termique	Leitung Kühler re- Thermostatschlauch	Tubo radiador der.-termostato
14	020390030 000	1		Tubo radiatore sx-termostato	L.H. Radiator-Thermostat hose	Tuyau radiateur G.-interrupteur termique	Leitung Kühler li- Thermostatschlauch	Tubo radiador izq.-termostato
15	020390020 000	1		Tubo inf. Termostato	Thermostat lower hose	Tube inf. interrupteur termique	Thermostatschlauch, unten	Tubo inf. Termostato
16	020390150 000	1		Tubo sovrappressione	Overpressure hose	Tuyau surpression	Kühlerschlauch Überdruck	Tubo sobre presión
17	020390140 000	3		Vite	Screw	Vis	Schraube	Tornillo
18	020390120 000	1		Coperchio termostato	Thermostat cover	Couvercle du thermostat	Thermostatabdeckung	Tapa del termostato
19	020390130 000	1		Termostato	Bimetal, thermostatic	Thérmostat	Thermostat	Termostato
20	1066830 000	1		Anello or 32x2	O-Ring 32x2	Bague d'étanchéité 32x2	O-Ring 32x2	Anillo OR 32x2
21	020390110 000	1		Contenitore termostato	Thermostat container	Logement interrupteur termique	Rahmen Thermostatschlauch	Plástico termostato
22	020390138 000	1		Termostato completo	Thermostat, assy	Thermostat complet	Thermostat komplett	Termostato compl.
23	1147015 000	4		Bullone M6x12	Bolt M6x12	Boulon M6x12	Bolzen M6x12	Tornillo M6x12
24	2743250 000	4		Rondella 6x24	Washer 6x24	Rondelle 6x24	U.Scheibe 6x24	Arandela 6x24
25	1634911 000	4		Gommino	Rubber buffer	Caoutchouc	Gummi	Goma
26	1645544 159	1		Griglia radiatore dx.	RH Radiator grille	Calandre D.	Kühlergrill rechts	Reja del radiador der.
27	1645545 159	1		Griglia radiatore sx.	LH Radiator grille	Calandre G.	Kühlergrill links	Reja del radiador izq.
28	007450438 000	1		Kit elettroventola (opzionale)	Electric fan kit (optional)	Jeu electro-ventilateur (Option)	Elektroluterradsatz (Optionsbaustein)	Kit electroventilador (opcional)

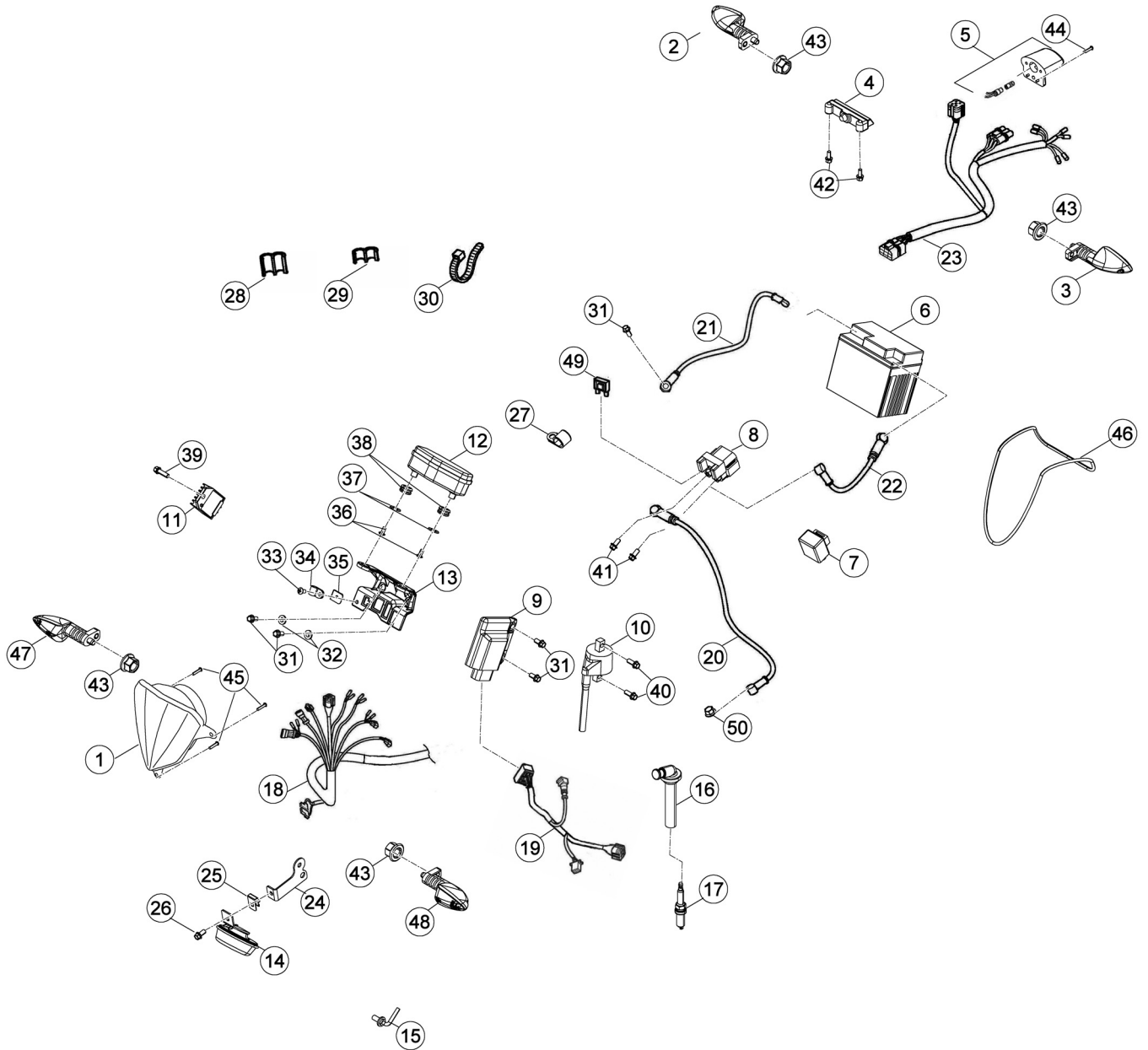

# Tav.26

Pos Loc Pos Ps Pos	Numero Number Numéro Número Nummer	Q.tà Q.ty Q.té M.ge C.ad	Nota Note Note Nota Anm.	Descrizione	Description	Désignation	Beschreibung	Descrìcion
1	1646210 000	1		Faro ant.	Headlamp	Projecteur	Scheinwerfer	Faro del.
2	1812621 000	2		Indicatore direzione post. dx	RH rear indicator	Indicateur arriere droit	Blinker hinten re.	flecha posterior derecha
3	1812624 000	2		Indicatore direzione post. sx	LH rear indicator	Indicateur arriere gauche	Blinker hinten li.	flecha posterior izquierda
4	020400308 000	1		Fanalino posteriore a led	LED tail lamp	Feu AR. à diodes	LED-Rücklicht	Piloto a LED
5	020400200 000	1		Luce Targa	Plate Illumination	Éclairage De Plaque	Kenzeichen-Beleuchtung	Illumnación Placa
6	1115416 000	1		Batteria	Battery	Batterie	Batterie	Bateria
7	1884946 000	1		Intermittenza	Unit turn signal lamps	Disp. comm. clignot.	Blinkgeber	Disp. intermitentes
8	2728471 000	1		Relais	Relay	Relais	Relay	Relé
9	020103008 000	1	350	Centralina digitale	CDI unit	Bobine digital (C.D.I.)	Steuergerät	Centralita digital
9	020100008 000	1	400	Centralina digitale	CDI unit	Bobine digital (C.D.I.)	Steuergerät	Centralita digital
9	020101008 000	1	450	Centralina digitale	CDI unit	Bobine digital (C.D.I.)	Steuergerät	Centralita digital
9	020102008 000	1	520	Centralina digitale	CDI unit	Bobine digital (C.D.I.)	Steuergerät	Centralita digital
9	020450218 000	1	400 FACT.	Centralina digitale doppia mappa	CDI unit double map	Bobine digital (C.D.I.) double carte	Steuergerät doppelteis kennfeld	Centralita digital doble mapa
9	020450228 000	1	450 FACT.	Centralina digitale doppia mappa	CDI unit double map	Bobine digital (C.D.I.) double carte	Steuergerät doppelteis kennfeld	Centralita digital doble mapa
9	020450238 000	1	520 FACT.	Centralina digitale doppia mappa	CDI unit double map	Bobine digital (C.D.I.) double carte	Steuergerät doppelteis kennfeld	Centralita digital doble mapa
10	006400108 000	1		Bobina accensione	Ignition coil	Bobine allumage	Zuendspule	Bobina de encendido
11	2728101 000	1		Regolatore	Regulator	Régulateur	Regler	Regulador
12	1209372 000	1	350	Strumento	Instrument	Instrument	Instrument	Instrumento
12	020404100 000	1	400-450	Strumento	Instrument	Instrument	Instrument	Instrumento
13	2898078 000	1	350	Supporto strumento	Instrument holder	Support instruments	Instrumentenhalter	Soporte instrumentos
13	020404110 000	1	400-450	Supporto strumento	Instrument holder	Support instruments	Instrumentenhalter	Soporte instrumentos
14	007400500 000	1		Avvisatore acustico	Warning horn	Avertisseur sonore	Hupe	Claxon
15	2879013 000	1		Sensore REED	REED sensor	Sensor REED	Sensor	Sensor REED
16	006100550 000	1		Cappuccio candela	Spark plug cap	Capuchon/couvercle bougie	Zündkerzenkappe	Capuchón de la bujia
17	006100500 000	1		Candela M12X1,25	Spark.plug M12X1,25	Bougie M12X1,25	Zundkerze M12X1,25	Bujia M12X1,25
18	020400000 000	1	350	Impianto centrale	Electric equipment	Installation centrale	Zentraler Kabelbaum	Instalacion central
18	020404000 000	1	400-450	Impianto centrale	Electric equipment	Installation centrale	Zentraler Kabelbaum	Instalacion central
18	020405000 000	1	FACTORY	Impianto centrale	Electric equipment	Installation centrale	Zentraler Kabelbaum	Instalacion central
19	020400050 000	1		Gruppo cavetti centralina iniezione	Injection power unit harness	Groupe fils centrale injection	Kabeleinheit Steuergerät	Conjunto cables centralita de inyección
20	020400040 000	1		Cavetto relè avviamento	Starter relay cable	Câble relais de demarrage	Anlassrelaiskabel	Cable relé de arranque
21	020400020 000	1		Cavetto di massa	Ground cable	Cable masse	Masse kabel	Cable masa
22	020400030 000	1		Cavo batteria-relè	Battery-Relay cable	Cable batterie-realis	Kabel Batterie-Relais	Cable Bateria-Relé
23	020400010 000	1		Impianto posteriore	Rear harness	Circuit post.	Anlage hinten	Instalación tras.
23	1801643 000	1	FACTORY	Impianto posteriore	Rear harness	Circuit post.	Anlage hinten	Instalación tras.
24	2897255 000	1		Staffa supporto claxon	Horn support bracket	Bride support avertisseur	Hupebefestigung	Brida soporte claxon
25	2560311 000	1		Piastrina elastica M6	Spring plate M6	Plaqueette élastique M6	Plättchen M6	Pletina elástica M6
26	1147015 000	1		Bullone M6x12	Bolt M6x12	Boulon M6x12	Bolzen M6x12	Tornillo M6x12
27	1514654 000	1		Fascetta	Clamp	Collier	Schelle	Abrazadera
28	2524442 000	1		Passacavo 6/8	Fair lead 6/8	Passe-fils 6/8	Kabelführung 6/8	Pasa-cable 6/8
29	2524443 000	3		Passacavo 6/6	Fair lead 6/6	Passe-fils 6/6	Kabelführung 6/6	Pasa-cable 6/6
30	1514264 000	1		Fascetta	Clamp	Collier	Schelle	Abrazadera
31	1147015 000	4		Bullone M6x12	Bolt M6x12	Boulon M6x12	Bolzen M6x12	Tornillo M6x12
32	1354820 000	2		Distanziale 6,5x9,0x13,5	Spacer 6,5x9,0x13,5	Entretaise 6,5x9,0x13,5	Distanzstück 6,5x9,0x13,5	Distanciador 6,5x9,0x13,5
33	3123530 000	1		Vite M4,2x16 TMTIC	Screw M4,2x16 TMTIC	Vis M4,2x16 TMTIC	Schraube M4,2x16 TMTIC	Tornillo M4,2x16 TMTIC
34	2525180 000	1		Passacavo	Grommet	Passe-câble	Kabeldurchgang	Pasacables
35	2558090 000	1		Piastrina elastica	Spring plate	Plaqueette élastique	Plättchen	Pletina elástica
36	3124620 000	2	350	Vite M5x11	Screw M5x11	Vis M5x11	Schraube M5x11	Tornillo M5x11
36	3123370 000	2	400-450	Vite M4x11	Screw M4x11	Vis M4x11	Schraube M4x11	Tornillo M4x11
37	2734800 000	2		Rondella 5x15	Washer 5x15	Rondelle 5x15	U.Scheibe 5x15	Arandela 5x15
38	1634915 000	2		Gommino	Rubber buffer	Caoutchouc	Gummi	Goma
39	1148025 000	1		Bullone 6x16 ch rs	Bolt 6x16 ch rs	Boulon 6x16 ch rs	Bolzen 6x16 ch rs	Tornillo 6x16 ch rs
40	1148025 000	2		Bullone 6x16 ch 8 rs	Bolt 6x16 ch 8 rs	Boulon 6x16 ch 8 rs	Bolzen 6x16 ch 8 rs	Tornillo 6x16 ch 8 rs
41	3130190 000	2		Vite a brugola 6x8	Allen screw 6x8	Vis à 6 pans 6x8	Sechskantschraube 6x8	Tornillo a llave allen 6x8
42	1146251 000	2		Bullone flangiato M5x12	Head Flanged bolt M5x12	Boulon Bridé M5x12	Bundbolzen M5x12	Bulón con Brida M5x12
43	1317121 000	4		Dado speciale M8	Special nut M8	Ecrou spéciale M8	Spezialmutter M8	Tuerca especial M8
44	3123565 000	1		Vite 4,5x15 TCCCR	Screw 4,5x15 TCCCR	Vis 4,5x15 TCCCR	Schraube 4,5x15 TCCCR	Tornillo 4,5x15 TCCCR
45	3126190 000	3		Vite M4x12 TCIC	Screw M4x12 TCIC	Vis M4x12 TCIC	Schraube M4x12 TCIC	Tornillo M4x12 TCIC
46	1440020 000	1		Cinghia fiss. batteria	Battery sec. strap	Bande fix. batterie	Batteriebefestigung Riemen	Correja suj. batería
47	1812611 000	1		Indicatore direzione ant. dx	RH front indicator	Indicateur avant droit	Blinker vorne re.	Flecha anterior derecha
48	1812614 000	1		Indicatore direzione ant. sx	LH front indicator	Indicateur avant gauche	Blinker vorne li.	Flecha anterior izquierda
49	1566601 000	2		Fusibile 10 A	Fuse 10 A	Fusible 10 A	Sicherung 10 A	Fusible 10 A
50	1312550 000	1		Dado flangiato M6	Flanged nut M6	Ecrou bordé M6	Flanschmutter M6	Tuerca embreadada M6

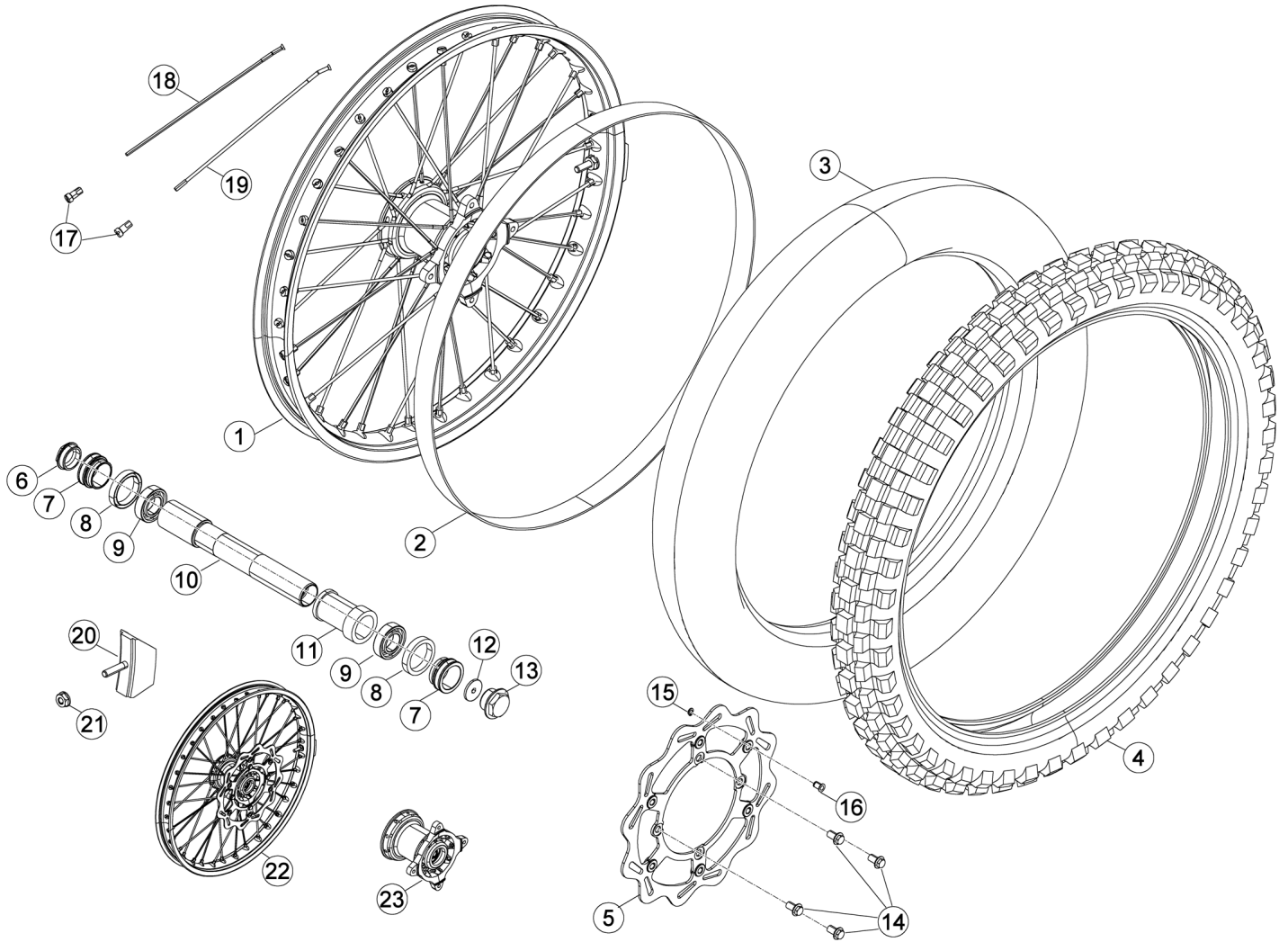



# Tav.27

Pos Loc Pos Ps Pos	Numero Number Numéro Número Nummer	Q.tà Q.ty Q.té M.ge C.ad	Nota Note Note Nota Anm.	Descrizione	Description	Désignation	Beschreibung	Descripcìon
1	1242901 059	1		Cerchio anteriore 21x1,6	Front rim 21x1,6	Jante avant 21x1,6	Vorderfelge 21x1,6	Llanta delantera 21x1,6
2	1538200 000	1		Flap 21x25	Bead 21x25	Flap21x25	Felgenband 21x25	Flap cinta tapa radios 21.25
3	1215005 000	1		Camera d'aria	Tubular braid	Chambre à air	Schlauch	Camara
4	1281575 000	1		Pneumatico	Tyre	Pneu	Reifen	Neumático
5	1339578 000	1		Disco freno	Brake plate	Disque frein	Bremscheibe	Disco freno
5	020410020 000	1	FACTORY	Disco freno	Brake plate	Disque frein	Bremscheibe	Disco freno
6	020410070 000	1		Tappo perno ruota anteriore	Front wheel pin plug	Bouchon pivot roue avant	Stopfen Pin Vorrad	Tapon eje rueda anterior
6	020410200 000	1	FACTORY	Tappo perno ruota anteriore	Front wheel pin plug	Bouchon pivot roue avant	Stopfen Pin Vorrad	Tapon eje rueda anterior
7	020410400 000	2		Distanziale ant.	Front spacer	Entretoise AV.	Distanzstück vorderer	Distanciador del.
8	1066000 000	2		Paraolio 35x47x7	Oil seal 35x47x7	Pare-huile 35x47x7	Dichtring 35x47x7	Sello de lub. 35x47x7
9	020410030 000	2		Cuscinetto 30x47x9	Bearing 30x47x9	Roulement 30x47x9	Lager 30x47x9	Cojinete 30x47x9
10	020410050 000	1		Perno ruota anteriore	Front wheel spindle	Pivot roue AV.	Vorderradzapfen	Perno ruota delantera
11	1362708 000	1		Distanziale interno	Inner spacer	Entretoise interne	Inneres Distanzstück	Distanciador interior
12	020411100 000	1		Vite speciale	Special screw	Vis spéciale	Spezialschraube	Tornillo especial
13	020410060 000	1		Tappo filettato	Threaded plug	Bouchon fileté	Gewindepfropf	Tapòn filete
14	1152515 000	4		Vite M8x14	Screw M8x14	Vis M8x14	Schraube M8x14	Tornillo M8x14
15	2822570 000	1		Seeger RA5	Circlip RA5	Circlip RA5	Seeger RA5	Seeger RA5
16	021410050 000	1		Magnete	Sensor magneto	Magneto capteur	Magnet für Sensor	Magneto sensor
17	007420140 000	36	◆	Nipplo	Nipple	Ecrou	Nippel	Tuerca
17	020410130 000	36	★	Nipplo	Nipple	Ecrou	Nippel	Tuerca
18	020410110 000	36	◆	Raggio	Spoke	Rayon	Speiche	Radio
18	020410120 000	18	★	Raggio	Spoke	Rayon	Speiche	Radio
20	1517551 000	1		Fermafascione	Tyre retainer	Arrêt	Felgenhalterung	Sujeta cobertura
21	1317120 000	1		Dado M8 flangiato	Nut M8	Ecrou M8	Mutter M8	Tuerca M8
22	020410000 059	1		Ruota anteriore	Fr.wheel	Roue AV.	Vorderrad	Rueda delantera
22	020413000 059	1	FACTORY	Ruota anteriore	Fr.wheel	Roue AV.	Vorderrad	Rueda delantera
23	016410100 000	1		Mozzo anteriore c/cuscinetti	Front hub with ballbearing	Moyeu avant avec roulements	Nabe vo.	Buje ant.c/cojinetes

★	Raggio con (A) sulla testa - Spoke marked with (A) - Rayon marqué avec (A) sur la tête - Speiche mit (A) markiert - Radio marcado con el simbolo (A)
◆	Raggio senza (A) sulla testa - Spoke no marked with (A) - Rayon sans (A) sur la tête - Speiche ohne das Symbol (A) - Radio sin el simbolo (A)

# Tav.28

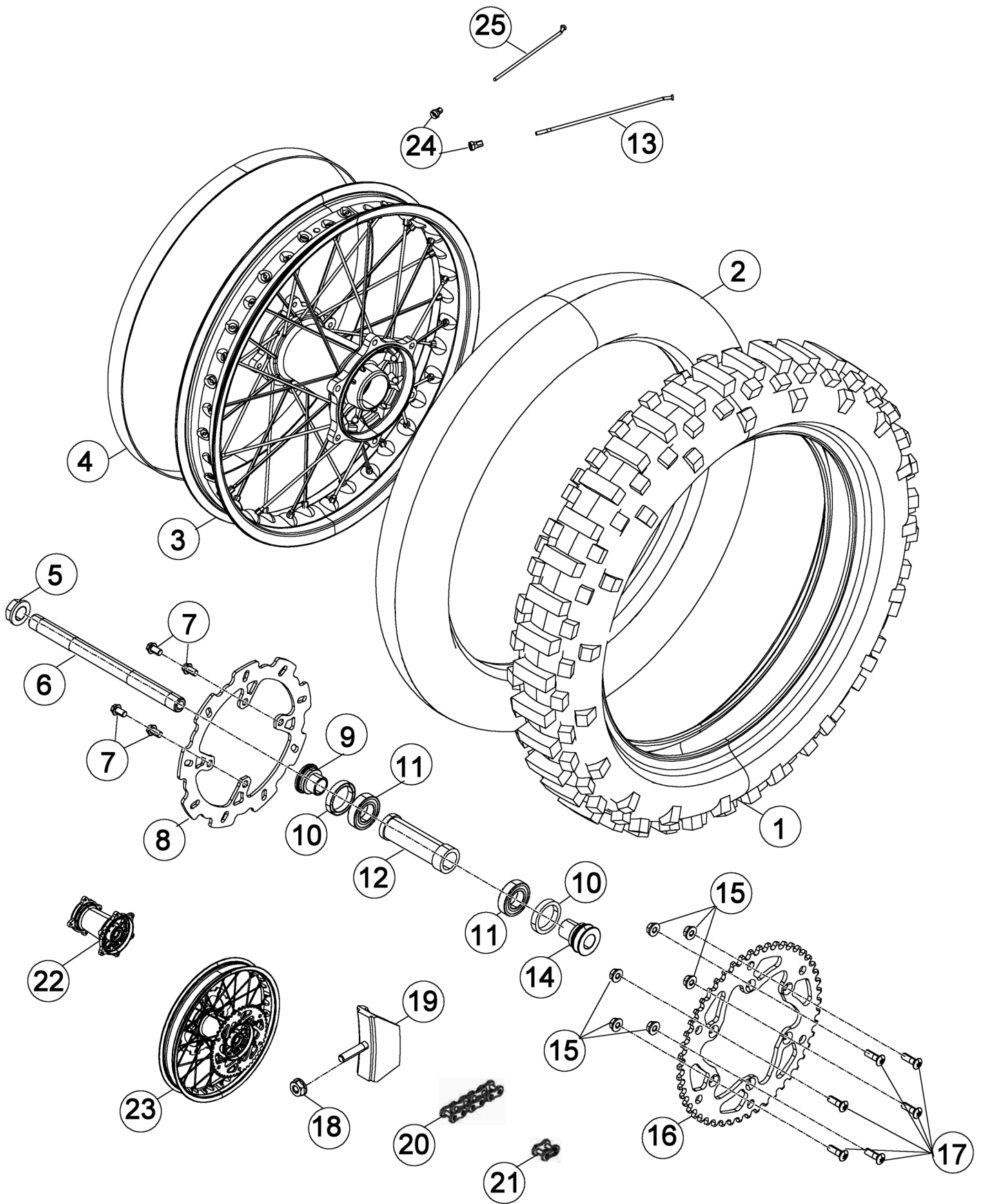

# Tav.28

Pos Loc Pos Ps Pos	Numero Number Numéro Número Nummer	Q.tà Q.ty Q.té M.ge C.ad	Nota Note Note Nota Anm.	Descrizione	Description	Désignation	Beschreibung	Descripción
1	1281584 000	1		Pneumatico	Tyre	Pneu	Reifen	Neumático
2	1215006 000	1		Camera d'aria	Tubular braid	Chambre à air	Schlauch	Camara
3	1242902 059	1		Cerchio ruota posteriore 18x2,15	Rear wheel rim 18x2,15	Janta roue AR. 18x2,15	Hinterradfelge 18x2,15	Llanta rueda trasera 18x2,15
4	1536000 000	1		Flap 17/18x25	Bead 17/18x25	Flap 17/18x25	Felgenband 17/18x25	Flap cinta tapa radios 17/18x25
5	1327120 000	1		Dado speciale	Special nut	Ecrou spéciale	Spezialmutter	Tuerca especial
6	2555812 000	1		Perno ruota posteriore	Rear wheel pin	Pivot roue arrière	Hinterradbolzen	Perno rueda trasera
7	1152515 000	4		Vite M8x14	Screw M8x14	Vis M8x14	Schraube M8x14	Tornillo M8x14
8	1339574 000	1		Disco freno posteriore	Rear brake disk	Disque frein arrière	Hinterbrems Scheibe	Disco freno trasero
8	020420080 000	1	FACTORY	Disco freno posteriore	Rear brake disk	Disque frein arrière	Hinterbrems Scheibe	Disco freno trasero
9	020420030 000	1		Distanziale mozzo post. Dx	RH rear hub spacer	Entretoise moyeu arriere D.	Distanz li	Distanciadador buje tras. Der.
10	1066000 000	2		Paraolio 35x47x7	Oil seal 35x47x7	Pare-huile 35x47x7	Dichtring 35x47x7	Sello de lub. 35x47x7
11	020420040 000	2		Cuscinetto 25x47x12	Bearing 25x47x12	Roulement 25x47x12	Lager 25x47x12	Cojinete 25x47x12
12	020420050 000	1		Distanziale interno	Inner spacer	Entretoise interne	Inneres Distanzstück	Distanciadador interior
14	020420020 000	1		Distanziale mozzo post. Sx	LH rear hub spacer	Entretoise moyeu arriere G.	Distanz re	Distanciadador buje tras. Izq.
15	1317123 000	6		Dado TECF M8	Nut TECF M8	Ecrou TECF M8	Mutter TECF M8	Tuerca TECF M8
16	1289497 000	1	350-400	Corona Z50	Ring gear Z50	Couronne Z50	Zahnkranz Z50	Corona Z50
16	1289496 000	1	450-520	Corona Z48	Ring gear Z48	Couronne Z48	Zahnkranz Z48	Corona Z48
16	016420200 000	1	400	Corona Z50	Ring gear Z50	Couronne Z50	Zahnkranz Z50	Corona Z50
16	016423200 000	1	FACTORY 450-520	Corona Z48	Ring gear Z48	Couronne Z48	Zahnkranz Z48	Corona Z48
17	3196827 000	6		Vite speciale M8X26	Special screw M8X26	Vis spéciale M8X26	Spezialschraube M8X26	Tornillo especial M8X26
18	1317120 000	1		Dado M8 flangiato	Nut M8	Ecrou M8	Mutter M8	Tuerca M8
19	1517531 000	1		Fermafascioni	Tire fastener	Caoutchouc serrure chambre	Reifen Halter	Agarre cubierta ant.
20	1208206 000	1	350-400	Catena P114	Chain P114	Chaîne P114	Kette P114	Cadena P114
20	1208209 000	1	450-520	Catena P112	Chain P112	Chaîne P112	Kette P112	Cadena P112
21	2211224 000	1		Maglia congiunzione 5/8x1/4	Connecting link 5/8x1/4	Maillon jonction 5/8x1/4	Kettenschloss 5/8x1/4	Eganche cadena 5/8x1/4
22	020420018 800	1		Mozzo posteriore c/cuscinetti	Rear hub with ballbearing	Moyeu arriere avec roulements	Hinterrad Nabe	Buje del. c/cojinetes
23	020422000 059	1	350-400	Ruota posteriore	Rear wheel	Roue AR.	Hinterrad	Rueda trasera
23	020422100 059	1	450-520	Ruota posteriore	Rear wheel	Roue AR.	Hinterrad	Rueda trasera
23	020423000 059	1	400	Ruota posteriore	Rear wheel	Roue AR.	Hinterrad	Rueda trasera
23	020423100 059	1	FACTORY 450-520	Ruota posteriore	Rear wheel	Roue AR.	Hinterrad	Rueda trasera
24	016420130 000	36	◆	Nipplo	Nipple	Ecrou	Nippel	Tuerca
24	020420130 000	36	★	Nipplo	Nipple	Ecrou	Nippel	Tuerca
25	016420120 000	18	◆	Raggio lato disco	Spoke	Bras	Speiche	Radio
25	020420110 000	18	★	Raggio lato disco	Spoke	Bras	Speiche	Radio
26	016420110 000	18	◆	Raggio lato corona	Spoke	Bras	Speiche	Radio
26	020420120 000	18	★	Raggio lato corona	Spoke	Bras	Speiche	Radio

★	Raggio con (A) sulla testa - Spoke marked with (A) - Rayon marqué avec (A) sur la tête - Speiche mit (A) markiert - Radio marcado con el simbolo (A)
◆	Raggio senza (A) sulla testa - Spoke no marked with (A) - Rayon sans (A) sur la tête - Speiche ohne das Symbol (A) - Radio sin el simbolo (A)

# Tav.29

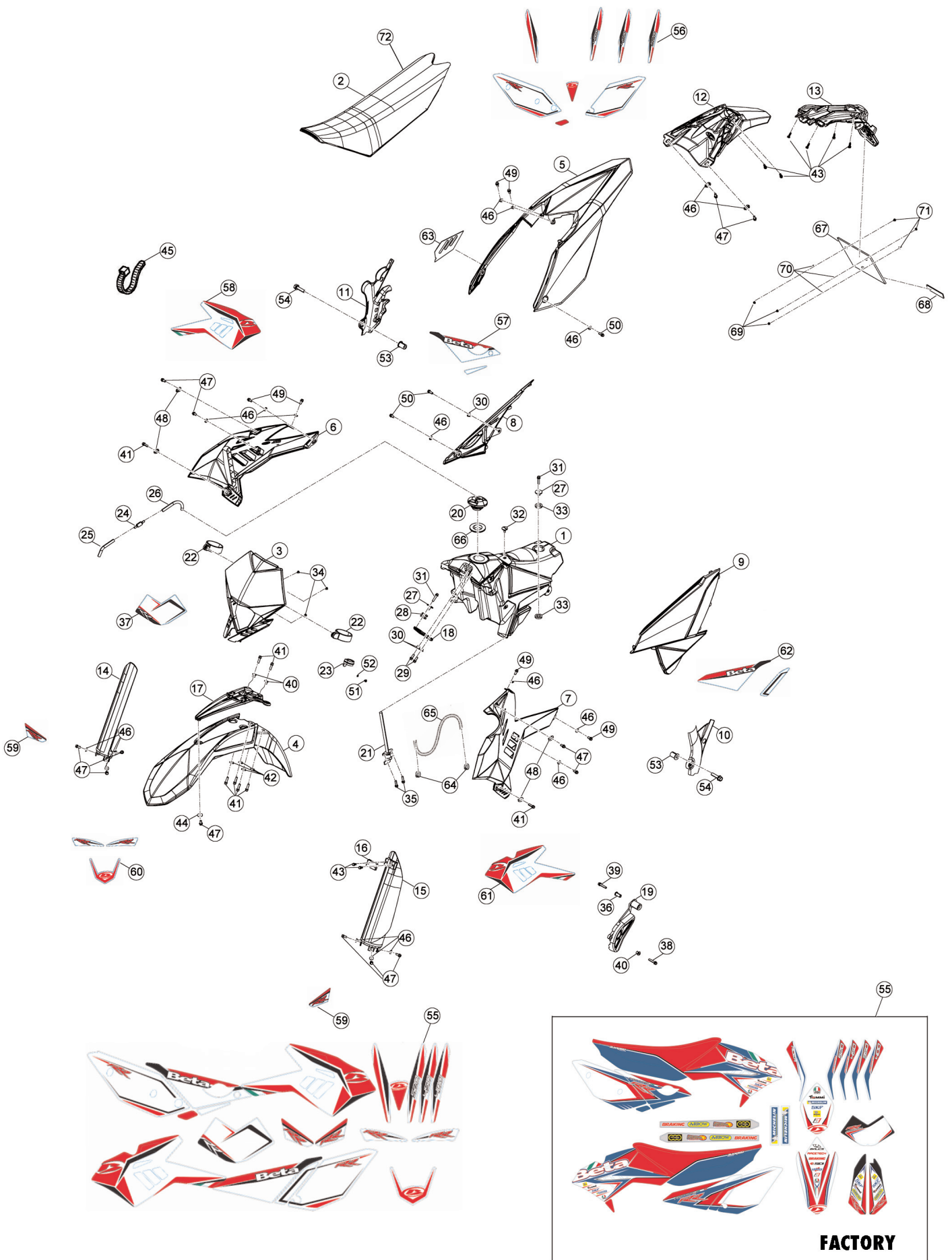

**Beta**  
the play bike

# Tav.29

Pos Loc Pos Ps Pos	Numero Number Numéro Número Nummer	Q.tà Q.ty Q.té M.ge C.ad	Nota Note Note Nota Anm.	Descrizione	Description	Désignation	Beschreibung	Descripción
1	020430001 059	1		Serbatoio	Fuel tank	Réservoir carburant	Kraftstofftank	Deposito gasolina
2	020431200 097	1		Sella	Seat	Siege	Sattel	Sillin
2	020432200 097	1	FACTORY	Sella	Seat	Siege	Sattel	Sillin
3	020430501 052	1		Mascherina	Mask	Masque	Maske	Máscara
4	020430401 051	1		Parafango	Mudguard	Garde-boue	Kotflügel	Guardabarros
5	020430301 051	1		Parafango posteriore	Rear mudguard	Garde-boue AR.	Hinterradkotflügel	Guardabarros tras.
6	020430101 051	1		Fianchetto radiatore dx	RH radiator panel	Cote lateral radiateur droite	Kühlerseite re.	Flanco derecho radiador
7	020430111 051	1		Fianchetto radiatore sx	LH radiator panel	Cote lateral radiateur droite	Kühlerseite re.	Flanco derecho radiador
8	020430331 059	1		Fianchetto scatola filtro dx	RH airbox panel	Cote lateral boîtier filtre à air d.	Luftfiltergehäusesseite re.	Flanco derecho caja filtro aire
9	020430321 059	1		Fianchetto scatola filtro sx	LH airbox panel	Cote lateral boîtier filtre à air g.	Luftfiltergehäusesseite li.	Flanco izquierdo caja filtro aire
10	020430601 059	1		Protezione telaio Sx	L.H. frame guard	Protection chassis G.	Rahmenschutz Links	Protección bastidor izquierda
10	020430640 000	1	FACTORY	Protezione telaio Sx carbonio	L.H. frame guard carbon	Protection chassis G. carbone	Rahmenschutz Links karbon	Protección bastidor izquierda carbono
11	020430611 059	1		Protezione telaio Dx	R.H. frame guard	Protection chassis D.	Rahmenschutz Rechts	Protección bastidor derecha
11	020430630 000	1	FACTORY	Protezione telaio Dx carbonio	R.H. frame guard carbon	Protection chassis D. carbone	Rahmenschutz Rechts karbon	Protección bastidor derecha carbono
12	020430311 059	1		Portatarga racing	Plate holder racing	Porte-plaque racing	Kennzeichenträger racing	Porta matr. Racing
13	020430341 059	1		Portatarga omologazione	Homologation plate holder	Porte-plaque homologation	Zulassungs Kennzeichenträger	Porta matr. Homologación
14	016340101 059	1		Protezione stelo dx.	R.H. Bellow protection	Protection tige D.	Schutzbalg R.	Protección varilla der.
15	016340111 059	1		Protezione stelo sx.	L.H. Bellow protection	Protection tige G.	Schutzbalg L.	Protección varilla izq.
16	2591330 159	1		Ponticello tubo freno	Brake pipe sprocket	Etrier tube frein	Bügel Bremsschlauch	Abrazadera tubo freno
17	020430411 059	1		Supporto parafango	Fender stay	Appui aile	Kotflügelstuetze	Soporte de guardabarros
18	020430011 059	1		Braccetto	Arm	Bras	Kleine Stütze	Brzo
19	020430621 059	1		Coperchio pignone	Sprocket cover	Couvercle pignon	Deckel Ritzel	Tapa piñón
20	2910500 159	1		Tappo serbatoio	Filler cap	Bouchon de réservoir	Tankverschluss	Tapón depósito
20	2910500 053	1	FACTORY	Tappo serbatoio	Filler cap	Bouchon de réservoir	Tankverschluss	Tapón depósito
21	020430070 000	1		Rubinetto benzina	Fuel cock.	Robinet melange	Kraftstoffhahn	Grifo mezcla
22	1440081 000	2		Elastico fissaggio mascherina	Headlight holder elastic rubber	Elastique de fixation cache phare	Befestigungsband Lichtschildchen	Elastico
23	2524464 000	1		Passacavo	Grommet	Passe-câble	Kabeldurchgang	Pasacables
24	3102170 000	1		Valvola sfiato serbatoio	Reservoir breather valve	Reniffard réservoir	Behälterentlüftungsventil	Válvula alivio depósito
25	020430030 000	1		Tubo tappo-valvola sfiato	Plug-Bleeder valve pipe	Tuyau bouchon-soupape purge	Leitung Verschluß-Entlüftungsventil	Tubo tapón-válvula purga de aire
26	020430040 000	1		Tubo valvola sfiato-raccordo	Bleeder valve-union pipe	Tuyau soupape-Raccord purge	Leitung Entlüftungsventil-anschluss	Tubo válvula purga de aire-Unión
27	020430020 000	2		Distanziale serbatoio	Tank spacer	Entretoise réservoir	Distanz tank	Distanciadador tanque
28	2891946 000	1		Silentbloc	Silentbloc	Silentbloc	Puffer	Silent-block
29	1148025 000	2		Bullone 6x16 ch 8 rs	Bolt 6x16 ch 8 rs	Boulon 6x16 ch 8 rs	Bolzen 6x16 ch 8 rs	Tornillo 6x16 ch 8 rs
30	1362000 000	2		Distanziale	Spacer	Entretoise	Distanzstück	Distanciadador
31	1150300 000	2		Bullone M6x30	Bolt M6x30	Boulon M6x30	Bolzen M6x30	Tornillo M6x30
32	3189010 000	1		Vite spec. bloccaggio sella	Seat locking screw	Vis bloccage selle	Schraube	Tornillo bloqueo sillin
33	2910615 000	2		Tampone	Buffer	Silentbloc	Puffer	Silent-block
34	3126190 000	3		Vite M4x12 TCIC	Screw M4x12 TCIC	Vis M4x12 TCIC	Schraube M4x12 TCIC	Tornillo M4x12 TCIC
35	3130815 000	2		Vite autofilettante 6x20	Self tapping screw 6x20	Vis taraud 6x20	Schraube, Blech 6x20	Tornillo autorrosc. 6x20
36	1349189 000	1		Distanziale	Spacer	Entretoise	Distanzstück	Distanciadador
37	020431790 000	1		Decal per portanumero	L.H. transfer	Decalcomania G.	Abziehbild L.	Calcomania izq.
38	1150300 000	1		Bullone 6x30 ch rs	Bolt 6x30 ch rs	Boulon 6x30 ch rs	Bolzen 6x30 ch rs	Tornillo 6x30 ch rs
39	1150300 000	1		Bullone 6x30 ch rs	Bolt 6x30 ch rs	Boulon 6x30 ch rs	Bolzen 6x30 ch rs	Tornillo 6x30 ch rs
40	1349190 000	2		Distanziale 10mm	Spacer 10mm	Entretoise 10mm	Distanzstück 10mm	Distanciadador 10mm
41	1149070 000	8		Bullone 6x20 ch rs	Bolt 6x20 ch rs	Boulon 6x20 ch rs	Bolzen 6x20 ch rs	Tornillo 6x20 ch rs
42	1354841 000	4		Distanziale	Spacer	Entretoise	Distanzstück	Distanciadador
43	3130030 000	8		Vite autofilettante 6x15	Self tapping screw 6x15	Vis taraud 6x15	Schraube, Blech 6x15	Tornillo autorrosc. 6x15
44	2742000 000	1		Rondella 6x18	Washer 6x18	Rondelle 6x18	U.Scheibe 6x18	Arandela 6x18
45	1514264 000	1		Fascetta	Clamp	Callier	Schelle	Abrazadera
46	1354820 000	18		Distanziale 6,5x9,0x13,5	Spacer 6,5x9,0x13,5	Entretoise 6,5x9,0x13,5	Distanzstück 6,5x9,0x13,5	Distanciadador 6,5x9,0x13,5
47	1147015 000	13		Bullone M6x12	Bolt M6x12	Boulon M6x12	Bolzen M6x12	Tornillo M6x12
48	020430120 000	4		Distanziale	Spacer	Entretoise	Distanzstück	Distanciadador
49	3195510 000	6		Vite TBCE M6x12	Screw TBCE M6x12	Vis TBCE M6x12	Schraube TBCE M6x12	Tornillo TBCE M6x12
50	1148025 000	3		Bullone 6x16 ch 8 rs	Bolt 6x16 ch 8 rs	Boulon 6x16 ch 8 rs	Bolzen 6x16 ch 8 rs	Tornillo 6x16 ch 8 rs
51	3123360 000	1		Vite autofilettante 4x10	Self tapping screw 4x10	Vis taraud 4x10	Schraube, Blech 4x10	Tornillo autorrosc. 4x10
52	2734650 000	1		Rondella	Washer	Rondelle	U.Scheibe	Arandela
53	1629620 000	2		Gommino fissaggio	Fastening rubber	Caoutchouc de fix.	Gummi Befestigung	Goma fijación
54	1146401 000	2		Bullone M5x20	Bolt M5x20	Boulon M5x20	Bolzen M5x20	Tornillo M5x20
55	020431708 000	1		Kit decalco completo	Trimmings kit, assy	Jeu enjoliv. Complet	Abziehbildsatz, kpl.	Juego calcom. compl.
55	020432708 000	1	FACTORY	Kit decalco completo	Trimmings kit, assy	Jeu enjoliv. Complet	Abziehbildsatz, kpl.	Juego calcom. compl.
56	020431718 000	1		Decal. parafango post.	Rear mudguard trim	Décal. garde-boue Ar.	Hinterradkotflügel Abziehbild	Calcom. guarda-barros tras.
57	020431728 000	1		Decalco per fianchetto Dx	R.H. transfer	Decalcomania D.	Abziehbild R.	Calcomania der.
58	020431730 000	1		Decal. convogliatore Dx.	R.H. trim	Décal. D.	Abziehbild R.	Calcom. der.

# Tav.29

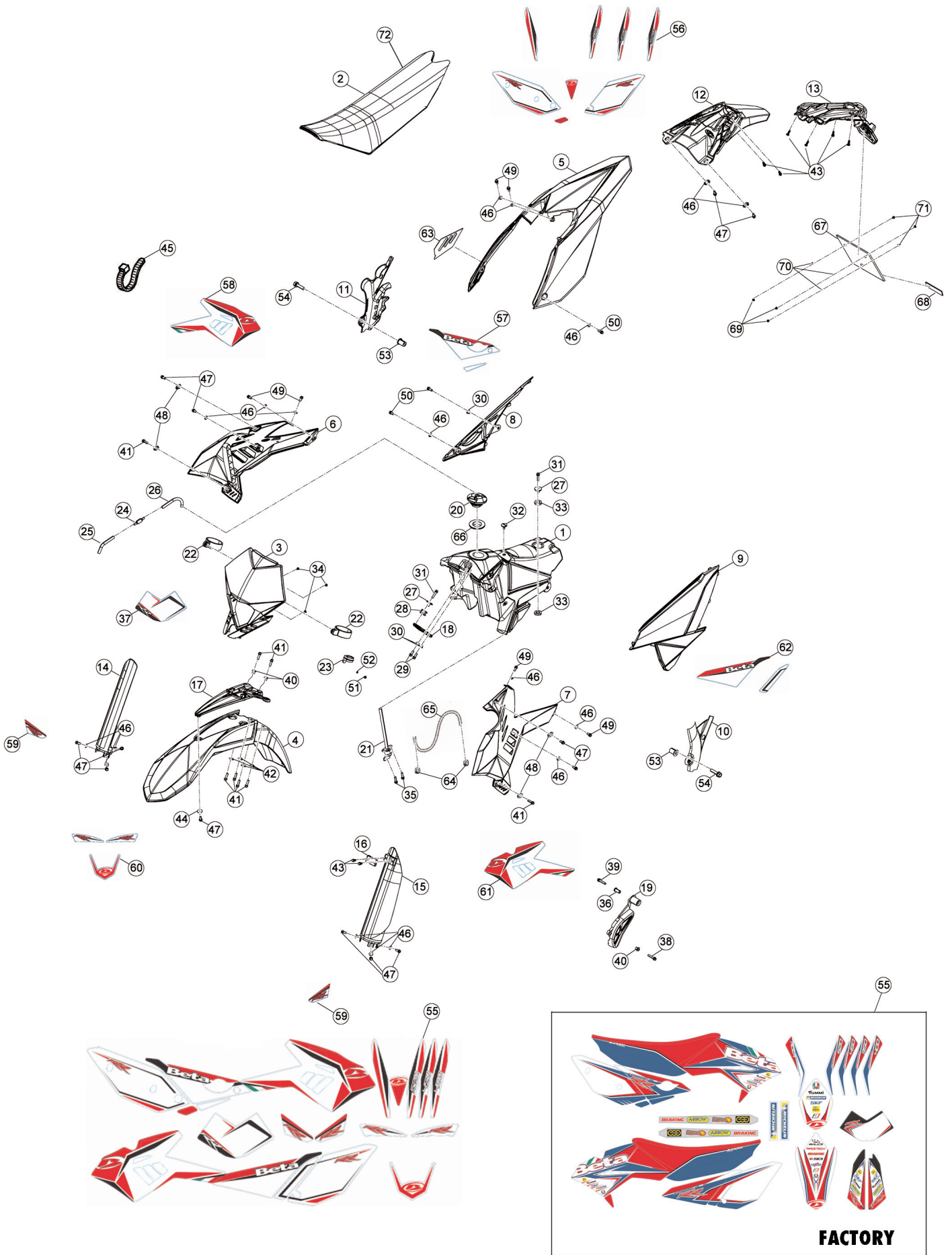

# Tav.29

Pos Loc Pos Ps Pos	Numero Number Numéro Número Nummer	Q.tà Q.ty Q.té M.ge C.ad	Nota Note Note Nota Anm.	Descrizione	Description	Désignation	Beschreibung	Descripcìon
59	020431748 000	1		Decal. protezione stelo	Bellow protection trim	Décal. protection tige	Abziehbildsatz Schutzbalg	Calcom. protección varilla
60	020431758 000	1		Decal. parafango ant.	Front mudguard trim	Décal. garde-boue Av.	Vorderradkotflügel Abziehbild	Calcom. guarda-barras del.
61	020431760 000	1		Decal. convogliatore Sx.	L.H. trim	Décal. G.	Abziehbild L.	Calcom. izq.
62	020431778 000	1		Decalco per fianchetto Sx	L.H. transfer	Decalcomania G.	Abziehbild L.	Calcomania izq.
63	020430350 000	1		Protezione Calore	Heat protection	Protection thermique	Hitzeschutz	Protección calor
64	1067460 000	1		Anello stringitubo	Pipe clamping ring	Anneau serre-tube	Schlauchschele	Anillo prensatubo
65	020430050 000	1		Tubo serbatoio-carburatore	Tank-carburettor pipe	Tuyau réservoir-carburateur	Tankleitung-Vergaser	Tubo radiador-carburador
66	1647498 000	1		Guarnizione tappo	Packing for cap	Joint bouchon	Deckeldichtung	Junta tapón
67	018430101 059	1		Supporto targa	Licence plate bracket	Support plaque	Nummernschildträger	Soporte placa porta matrícula
68	1233086 000	1		Catadiottro posteriore	Rear reflector	Catadioptré AR.	Rückstrahler hinten	Catafaro tras.
69	1311010 000	3		Dado autobloccante M5	Self locking nut M5	Ecrou de sécurité M5	Mutter, selbstsichernd M5	Tuerca de seguridad M5
70	2736000 000	3		Rondella 5x11	Washer 5x11	Rondelle 5x11	U.Scheibe 5x11	Arandela 5x11
71	3129860 000	3		Vite M5x16 TTLIC	Screw M5x16 TTLIC	Vis M5x16 TTLIC	Schraube M5x16 TTLIC	Tornillo M5x16 TTLIC
72	020432211 000	1	FACTORY	Coprisella antiscivolo	Saddle cover	Housse de selle	Sitzbankschutz	Cubresillin

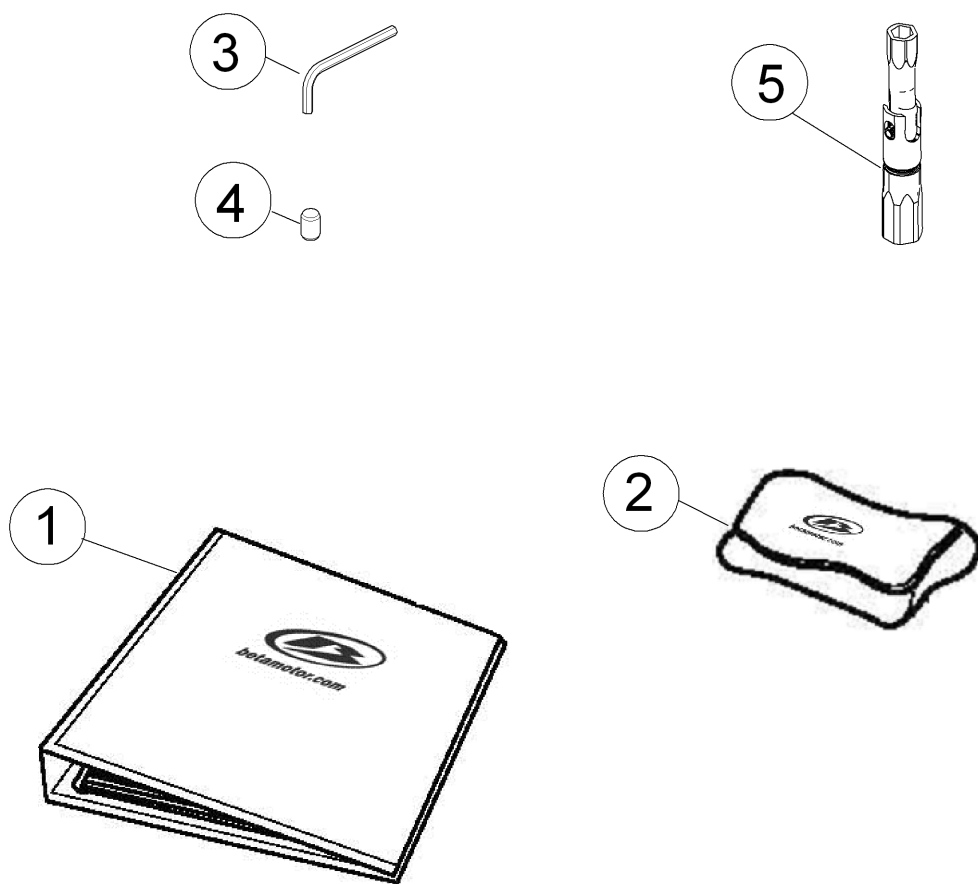

Pos Loc Pos Ps Pos	Numero Number Numéro Número Nummer	Q.tà Q.ty Q.té M.ge C.ad	Nota Note Note Nota Anm.	Descrizione	Description	Désignation	Beschreibung	Descripción
1	020440070 000	1		Manuale uso e manutenzione	Owner's manual	Manuel d'utilisation et entretien	Bedienungs und Wartungshandbuch	Manual de Uso y Manutención
2	020441028 000	1		Borsa attrezzi	Tool roll	Trousse à outils	Werkzeugtasche	Bolsa herramientas
3	020440030 000	1		Chiave a brugola 6mm	Allen wrench 6mm	Clé Allen 6mm	Sechskantschlüssel 6mm	Llave de imbus 6mm
4	020440040 000	1		Bussola 8	Bush 8	Joint 8	Buchse 8	Buje 8
5	020440100 000	1		Chiave candela	Ignition wrench	Clé à bougie	Zündkerzenschlüssel	Llave bujía







Handwriting practice area consisting of 20 horizontal dotted lines.



---

Dotted lines for writing.

